

# BOARD OF COUNTY COMMISSIONERS OF DOUGLAS COUNTY, KANSAS

## MONDAY, APRIL 7, 2014

9:00 a.m.

-Lecompton Election Canvass

### Special Meeting of the County Commission

Immediately following the Canvass:

### CONSENT AGENDA

- (1) (a) Consider approval of Commission Orders;
- (b) Consent authorization to renew pavement markings contract (Keith Browning);
- (c) Consider a purchase of a lowboy trailer for Public Works (Jackie Waggoner);
- (d) Consider accessing HGAC Contract to purchase a Bobcat for the Public Works Department (Jackie Waggoner);
- (e) Consider approval of contract for Dust Palliative supply and application (Keith Browning); and
- (f) Consider acceptance of bids for Various Signs, Posts and Miscellaneous Materials for Public Works (Keith Browning)

### REGULAR AGENDA

- (2) Consider approval of agreement with Federal Highway Administration for Federal Lands Access Program (FLAP) funding for Project No. 2012-14, Route 458 improvements from E1050 to US-59 highway (Keith Browning)
- (3) Consider authorization to solicit bids for Project No. 2012-14, Route 458 improvements from E1050 to US-59 highway (Keith Browning)
- (4) Consider approval of agreement with KDHE for funding to clean up illegal dump in Eudora Township (Keith Browning)
- (5) Consider resolution authorizing the installation of a gate across E 2000 Road just south of K-10 highway (Keith Browning)
- (6) Adjourn

## WEDNESDAY, APRIL 9, 2014 -Canceled

## WEDNESDAY, APRIL 16, 2014

- Proclamation for National Public Safety Telecommunicator's Week April 13-19, 2014 (Scott Ruf)
- Consider approval of FY2015 Comprehensive Plan/Budget for Community Corrections (Deborah Ferguson)
- Consider approval of Health Insurance Stop-Loss Coverage (Sarah Plinsky)
- Consider resolution to amend Douglas County zoning regulations 12-319-7 regarding agritourism regulations (Linda Finger)

6:35 p.m.

-CUP-14-00064 (CUP-12-16-02) 5-year compliance review and reclamation plans for Hamm Eudora Quarry #58 located on approximately 129 acres at, and north of, 1232 E 2300 Road. Mary Miller will present the item.

**WEDNESDAY, APRIL 23, 2014**

**WEDNESDAY, APRIL 30, 2014**

4:00 p.m.

-Presentation of Report from Lawrence-Douglas County Advocacy Council on Aging (Judy Bellome)

**WEDNESDAY, JUNE 4, 2014**

-Consider a proclamation for "Relay for Life Week" (Betty Parks)

***Note:** The Douglas County Commission meets regularly on Wednesdays at 4:00 P.M. for administrative items and 6:35 P.M. for public items at the Douglas County Courthouse. Specific regular meeting dates that are not listed above have not been cancelled unless specifically noted on this schedule.*

## **MEMORANDUM**

To : Board of County Commissioners

From : Keith A. Browning, P.E., Director of Public Works/County Engineer

Date : March 31, 2014

Re : Consent Agenda authorization to renew pavement markings contract

This department contracts for supplying materials and painting pavement markings on county routes. Pavement markings typically need repainting annually. The BOCC executed a contract in 2012 for pavement marking services, and the contract is renewable for an additional three years (through 2016). Douglas County determines whether to renew the contract following the contractor's submittal of prices each year.

Our current contract is with Midwest Striping, Inc. from Grand Island, Nebraska. We have been extremely pleased with the quality of work and the responsiveness and cooperation from this contractor. This contractor provides excellent service at a reasonable cost.

Midwest Striping has submitted their prices for 2014 (see attached). The material cost and application cost for paint did not increase this year. The unit costs for painted symbols have not increased since 2007. The attached spreadsheet shows 2014 quantities and bid prices.

The total bid amount for 2014 pavement marking is \$148,974.59. Road & Bridge Fund 201 has \$155,742 allocated for this work.

I am also requesting authorization to approve change orders up to 5% of contract cost. The paint application rate will vary depending on pavement surface type and condition. Typically, our final costs are very close to the bid amount.

Action Required: Consent Agenda authorization for the Public Works Director to renew the contract with Midwest Striping, Inc. for 2014 pavement markings in the amount of \$148,974.59, and authorization for the Public Works Director to approve change orders totaling up to 5% over the contract amount.

BOND NO. 61968661

DOUGLAS COUNTY, KANSAS  
DOUGLAS COUNTY PROJECT NO. 2014-7  
BID # 12-F-0012

**PERFORMANCE BOND**

KNOW ALL MEN BY THESE PRESENTS THAT:

We, Midwest Striping, Inc., as Principal, and WESTERN SURETY COMPANY, a surety company duly authorized to do business in the State of Kansas, as Surety, are held and firmly bound unto the Board of County Commissioners of Douglas County, Kansas, as Obligee, in the penal sum of One Hundred Forty-Eight Thousand Nine Hundred Seventy-Five and no/100 Dollars (\$ 148,975.00) (the current amount of the contract price between Principal and Obligee), lawful money of the United States of America, for the payment of which sum well and truly to be made, bind ourselves, and our respective heirs, executors, administrators, successors, and assigns, jointly and severally, firmly by these presents.

THE CONDITION OF THE FOREGOING OBLIGATION IS SUCH THAT, WHEREAS, the Principal has, on \_\_\_\_\_, 20\_\_\_\_, entered into a written Agreement with the Obligee for furnishing labor, equipment, material, and supplies in connection with the installation, construction of or in making such improvements, equipment, and services described in said Agreement, all in accordance with the plans, specifications and other Contract Documents described therein and as supplemented and otherwise changed during the project. The Agreement (including but not limited to the plans, specifications and other Contract Documents) is by reference made a part hereof, and is hereinafter called the Contract.

NOW, THEREFORE, if the Principal shall and will, in all particulars, well, duly and faithfully observe, perform and abide by each and every covenant, condition, obligation and part of the Contract, according to the true intent and meaning in each case, and hold the Obligee harmless against all claims, loss or damage which it may sustain or suffer by reason of any breach of said Contract by said Principal or by reason of any injury to persons or property occasioned by the action of said Principal or its employees, and if said Principal maintains the improvement, equipment, and service as provided for in said Contract and make good all defects in materials and workmanship as required under the Contract, then this obligation shall be and become null and void; otherwise, it shall remain in full force and effect. Whenever the Principal is, and is declared by the Obligee to be, in default under the Contract, the Surety shall remedy the default at its

expense by promptly (a) completing the Contract in accordance with its terms and conditions, through its agents or independent contractors; or (b) obtaining a bid or bids for completing the Contract in accordance with its terms and conditions, and, upon determination by the Obligee of the lowest and best bid, arrange for an agreement between such bidder and the Obligee, secured by payment and performance bonds, and pay to Obligee the final cost of such agreements less the balance of the Contract Price, but not exceeding, including other costs and damages for which the Surety may be liable hereunder, the amount set forth in the first paragraph hereof as the same may be increased by change order(s) to the Contract as approved by the Obligee; or (c) work out such other arrangements as are accepted by Obligee in writing. The term "balance of the Contract Price," as used herein, shall mean the total amount payable by the Obligee to the Principal under the Contract, and any amendments thereto, less the amount paid by the Obligee to the Principal.

PROVIDED, FURTHER, that the Surety hereby stipulates and agrees, for value received, that no change, extension of time, modification, supplement, alteration or addition to the undertakings, covenants, terms or conditions of the Contract or the Undertaking, shall in any way affect its obligations on this bond. The Surety does hereby waive notice of any change, extension of time, modification, supplement, alteration or addition to the terms or conditions of the Contract or Undertaking. ~~The Surety stipulates and agrees that the penal sum of this bond shall be automatically increased or decreased by any change order(s) to the Contract as approved by the Obligee.~~ Principal and Surety further stipulate and agree that acceptance, approval or certification of completion of work under the Contract and/or payment (final or otherwise) by Obligee shall not relieve the Principal or Surety from any liability for any failure to fully perform the Contract or any other obligation on this bond.

Nonpayment of the bond premium will not invalidate this bond nor shall the Obligee be obligated for the payment of any bond premium.

IN WITNESS WHEREOF, the Principal and Surety have caused this bond to be duly signed this 14th day of March, 2014.

Midwest Striping, Inc.

Principal

By Curt Clueman

President  
(Official Title)

WESTERN SURETY COMPANY

Surety Company

By: 

(Attorney-In-Fact) JEFFREY L SCHULTZ

By: NOT NEEDED

(Kansas Agent)

(A certified copy of the Attorney-in-Fact's Power of Attorney from the Surety, to include the date and amount of the bond, must be attached to this bond).

Sufficiency of the Bond Approved by:

\_\_\_\_\_  
Chairperson of Board of County Commissioners

Date: \_\_\_\_\_

Form and Amount of Bond Approved By:

\_\_\_\_\_  
County Counselor

Date: \_\_\_\_\_

**NOTE:**

1. Date of bond must not be prior to date of Agreement.
2. If Principal is a partnership, all partners should execute bond.
3. Surety companies executing bonds must appear on the U.S. Department of the Treasury's most current listing of approved sureties (Department Circular 570, as amended), and be authorized to transact business in the State of Kansas.
4. Accompany this bond with Attorney-in-Fact's authority from the Surety certified to include the date of the bond.

# Western Surety Company

## POWER OF ATTORNEY - CERTIFIED COPY

Bond No. 61968661

Know All Men By These Presents, that WESTERN SURETY COMPANY, a corporation duly organized and existing under the laws of the State of South Dakota, and having its principal office in Sioux Falls, South Dakota (the "Company"), does by these presents make, constitute and appoint Jeffrey L Schultz

its true and lawful attorney(s)-in-fact, with full power and authority hereby conferred, to execute, acknowledge and deliver for and on its behalf as Surety, bonds for:

Principal: Midwest Striping, Inc.

Obligee: Board of County Commissioners of Douglas County

Amount: \$500,000.00

and to bind the Company thereby as fully and to the same extent as if such bonds were signed by the Senior Vice President, sealed with the corporate seal of the Company and duly attested by its Secretary, hereby ratifying and confirming all that the said attorney(s)-in-fact may do within the above stated limitations. Said appointment is made under and by authority of the following bylaw of Western Surety Company which remains in full force and effect.

"Section 7. All bonds, policies, undertakings, Powers of Attorney or other obligations of the corporation shall be executed in the corporate name of the Company by the President, Secretary, any Assistant Secretary, Treasurer, or any Vice President or by such other officers as the Board of Directors may authorize. The President, any Vice President, Secretary, any Assistant Secretary, or the Treasurer may appoint Attorneys in Fact or agents who shall have authority to issue bonds, policies, or undertakings in the name of the Company. The corporate seal is not necessary for the validity of any bonds, policies, undertakings, Powers of Attorney or other obligations of the corporation. The signature of any such officer and the corporate seal may be printed by facsimile."

All authority hereby conferred shall expire and terminate, without notice, unless used before midnight of February 1st, 2015, but until such time shall be irrevocable and in full force and effect.

In Witness Whereof, Western Surety Company has caused these presents to be signed by its Vice President, Paul T. Bruflat, and its corporate seal to be affixed this 14th day of March, 2014.



WESTERN SURETY COMPANY

Paul T. Bruflat  
Paul T. Bruflat, Vice President

STATE OF SOUTH DAKOTA }  
COUNTY OF MINNEHAHA } ss

On this 14th day of March, in the year 2014, before me, a notary public, personally appeared Paul T. Bruflat, who being to me duly sworn, acknowledged that he signed the above Power of Attorney as the aforesaid officer of WESTERN SURETY COMPANY and acknowledged said instrument to be the voluntary act and deed of said corporation.

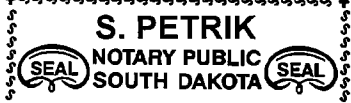

My Commission Expires August 11, 2016

S. Petrik  
Notary Public - South Dakota

I the undersigned officer of Western Surety Company, a stock corporation of the State of South Dakota, do hereby certify that the attached Power of Attorney is in full force and effect and is irrevocable, and furthermore, that Section 7 of the bylaws of the Company as set forth in the Power of Attorney is now in force.

In testimony whereof, I have hereunto set my hand and seal of Western Surety Company this 14th day of March, 2014.

WESTERN SURETY COMPANY

Paul T. Bruflat  
Paul T. Bruflat, Vice President

ACKNOWLEDGMENT OF SURETY

STATE OF Nebraska  
COUNTY OF Hall } ss

(Attorney-in-Fact)

Bond No. 61968661

On this 19th day of March, 2014, before me, a notary public in and for said County, personally appeared Jeffrey L Schultz to me personally known and being by me duly sworn, did say, that he/she is the Attorney-in-Fact of WESTERN SURETY COMPANY, a corporation of Sioux Falls, South Dakota, created, organized and existing under and by virtue of the laws of the State of South Dakota, that the said instrument was executed on behalf of the said corporation by authority of its Board of Directors and that the said Jeffrey L Schultz acknowledges said instrument to be the free act and deed of said corporation and that he/she has authority to sign said instrument without affixing the corporate seal of said corporation.

IN WITNESS WHEREOF, I have hereunto subscribed my name and affixed my official seal at Grand Island, Nebraska, the day and year last above written.

My commission expires Oct 1, 2015

Rosemary K. Johns

Notary Public

Form 106-9-2013

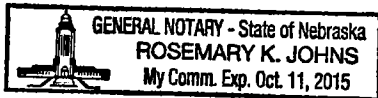





**DOUGLAS COUNTY ADMINISTRATIVE SERVICES**

**Division of Purchasing**

1100 Massachusetts Street  
Lawrence, KS 66044-3064  
(785) 832-5286 Fax (785) 838-2480  
www.douglas-county.com

---

**MEMO TO:** The Board of County Commissioners  
Craig Weinaug, County Administrator

**FROM:** Jackie Waggoner, Purchasing Director  
Division of Purchasing

**SUBJECT:** Consider Purchase of a Lowboy Trailer for Public Works

**DATE:** April 3, 2014

Public Works has funds allocated to replace a 1986 Trail King lowboy trailer. The trailer is primarily used to haul heavy equipment from project to project.

For the past few years the existing trailer has experience several mechanical issues, but more recently it has been determined that the three rear axles would need to be reconstructed. While this equipment was scheduled to be replaced this year, staff needs this equipment as soon as possible as the existing model is inoperable. As staff looked at our options, the three below are available for your consideration:

<b>Company</b>	<b>Model</b>	<b>Warranty</b>	<b>Availability</b>	<b>Cost</b>
G.W. Van Keppel	2013 Etnyre	1 Year	In stock KC	\$75,100
Murphy Tractor & Equipment	2012 Eager Beaver	1 Year	In stock KC	\$70,524
4 Rivers Equipment – HGAC	2014 Towmaster	1 Year	95 Days	\$83,170

In the past we would either solicit formal bids or seek your approval to access the HGAC (Houston-Galveston Area Council) contracts for this type of equipment. As you can see, we did receive a quote from HGAC and two local companies who have models in stock. Although each model is a different year they are all new. Public Works staff went and looked at the two models in stock to confirm they would meet their requirements. It is their preference to purchase the 2012 model from Murphy Tractor. The existing lowboy trailer would be sold through our online auction.

Doug Stephens and I will be available to answer any questions you may have.

**RECOMMENDATION:** The Board of County Commissioners authorizes staff to purchase a 2012 lowboy trailer from Murphy Tractor & Equipment in the amount of \$70,524.



## DOUGLAS COUNTY ADMINISTRATIVE SERVICES

### Division of Purchasing

1100 Massachusetts Street  
Lawrence, KS 66044-3064  
(785) 832-5286 Fax (785) 838-2480  
www.douglas-county.com

---

**MEMO TO:** The Board of County Commissioners  
Craig Weinaug, County Administrator

**FROM:** Jackie Waggoner, Purchasing Director  
Division of Purchasing

**SUBJECT:** Consider Accessing HGAC Contract to Purchase a Bobcat for Public Works

**DATE:** April 3, 2014

Public Works has allocated funds to replace their existing 2007 Bobcat S300 with approximately 3,000 hours. It is currently used by the asphalt crew for patching and repairing hard surfaced roads. The parks crew has the same Bobcat loader as the replacement model which will allow attachments to be shared.

Staff is interested in purchasing the following attachments with the equipment: 72" root grapple that is used to clean up trees and brush and will be a big asset for storm cleanup, pallet forks which may be used at various construction sites to unload and load material, 24" planer used to excavate smaller asphalt patches, and a stump grinder to remove stumps along right-of-way and parks.

The equipment is available through the Houston-Galveston Area Council's (HGAC) cooperative buying program. Mid-America Regional Council (MARC) established an inter-local agreement which extends cooperative contract pricing under HGAC to governments. This approach has proven to provide considerable savings, and allows us opportunities to make these purchases through authorized dealers in Kansas. HGAC cost for a Bobcat with the attachments identified above and an extended warranty of 36 months/3,000 hours is \$75,728.65. The 2007 Bobcat will be sold through our online auction.

Doug Stephens and I will be available at the commission meeting to answer questions.

**RECOMMENDATION:** The Board of County Commissioners authorizes staff to access the HGAC contract to purchase a Bobcat through K.C. Bobcat in the amount of \$75,728.65.

## MEMORANDUM

To : Board of County Commissioners

From : Keith A. Browning, P.E., Director of Public Works/County Engineer

Date : April 3, 2014

Re : Consent Agenda approval of contract for Dust Palliative supply and application

Bids for the supply and application of dust palliative material were opened April 1, 2014. We solicited bids for both 38% Calcium Chloride solution and 32% Magnesium Chloride solution. Only one supplier submitted a bid for 32% Magnesium Chloride. No bids were received for 38% Calcium Chloride.

### **Scotwood Industries, Inc.:**

<u>Item</u>	<u>Quantity</u>	<u>Unit Price</u>	<u>Total Price</u>
32% MgCl	85,000 gal	\$0.860	\$73,100

This year's bid unit price from Scotwood Industries is three cents higher than last year's price, which was \$0.830/gallon. The low-bid price should allow us to meet the target application rate of 0.45 gallons/square yard.

The number of applications this year is similar to last year (77 in 2014 and 71 in 2013). The gallons needed for this year has increased considerably (101,882 gallons in 2014 versus 77,380 in 2013).

In addition to the dust palliative material, we will hire a water truck to pre-wet all locations. This cost is included in the \$1.40/linear foot user fee.

Action Required: Consent Agenda approval to accept the low bid and award the contract for supply and application of 32% magnesium chloride solution for the user fee dust palliative program to Scotwood Industries, Inc. at a unit cost of \$0.860 per gallon.

**DUST PALLIATIVE**

**Bid No. 14-F-0003**

**Opening Date: Tuesday, April 1, 2014 @ 3:00 P M.**

PRODUCT	VENDOR	UNIT	QUANTITY	UNIT PRICE	TOTAL
38% Calcium Chloride	Scotwood Ind.	Gal.	85,000	No Bid	\$ -
32% Magnesium Chloride	Scotwood Ind.	Gal.	85,000	\$0.8600	\$ 73,100.00
					\$ -
					\$ -
38% Calcium Chloride		Gal.	85,000		\$ -
32% Magnesium Chloride		Gal.	85,000		\$ -
					\$ -
					\$ -
38% Calcium Chloride		Gal.	85,000		\$ -
32% Magnesium Chloride		Gal.	85,000		\$ -
					\$ -
					\$ -
38% Calcium Chloride		Gal.	85,000		\$ -
32% Magnesium Chloride		Gal.	85,000		\$ -

Rita Fulks for:  
\_\_\_\_\_  
Director of Public Works

4/1/2014  
\_\_\_\_\_  
Date

Ben Lampe for:  
\_\_\_\_\_  
County Clerk

**MEMORANDUM**

To : Board of County Commissioners

From : Keith A. Browning, P.E., Director of Public Works/County Engineer

Date : April 16, 2014

Re : Consent Agenda Acceptance of Bids for Various Signs, Posts and Miscellaneous Materials

Bids for finished signs, fluorescent signs, cut-out lettering, steel posts, telespar posts, and miscellaneous accessories were opened April 1st. Attached is a listing of all bids received. The lowest bid is recommended for each item or group of items, and shaded on the attached listing. The following awards are recommended:

Vulcan (Finished Signs)	\$16,167.15
Osburn Associates (Flour. Signs)	\$ 6,660.32
Ibis Tek (Cut-Out Lettering)	\$ 46.10
Ibis Tek (Steel Posts)	\$ 4,254.90
J & A Traffic (Telespar Posts)	\$ 4,645.00
CPC Signs (Temp. Pv'mt Marking Tape)	\$ 760.00
Osburn Associates (OM-3 Left Refaces)	\$ 48.30
Osburn Associates (OM-3 Right Refaces)	<u>\$ 48.30</u>
BID TOTAL	\$32,630.07

Sufficient funds are available in Fund 201, line items 71241, 71243 and 70400 to cover these items.

Action Required: Consent Agenda approval to award bids for various signs, posts, and miscellaneous materials as recommended by the Director of Public Works.

**BID TAB FOR SIGNS AND ACCESSORIES**

**BID NO. 14-F-0002- Bid Opening Date: April 1, 2014**

	<u>VENDOR</u>	<u>Finished Signs</u>	<u>Fluorescent Signs</u>	<u>Cut-Out Lettering</u>	<u>Steel Posts</u>	<u>Telespar Posts</u>	<u>Misc. Items</u>
1	National Sign Company, Inc.	\$24,696.48	\$8,426.59	\$83.00	\$4,682.30	\$5,269.75	\$1,267.00
2	Rocal, Inc.	\$21,023.18	\$8,827.59	No Bid	No Bid	No Bid	No Bid
3	M D Solutions	No Bid	No Bid	No Bid	\$4,438.50	No Bid	No Bid
4	Custom Products Corp.	\$19,121.26	\$7,051.34	\$54.91	\$5,396.40	\$8,038.85	\$862.20
5	IBIS Tek	\$38,764.53	\$13,451.52	\$46.10	\$4,254.90	\$6,520.00	Partial Bid
6	Newman Signs, Inc.	\$19,884.97	\$7,193.23	\$105.90	\$4,511.40	\$5,102.60	\$544.40
7	J & A Traffic Products	No Bid	No Bid	No Bid	No Bid	\$4,645.00	No Bid
8	Vulcan Signs	\$16,167.15	\$7,099.71	\$75.00	\$5,216.40	\$5,525.65	Partial Bid
9	Osburn Signs	\$15,997.46	\$6,660.32	No Bid	No Bid	No Bid	Paritial Bid
10							
11							
12							
13							
14							
15							
16							
17							
18							
19							
20							
21							
22							
23							
24							
25							
26							
27							
28							
29							

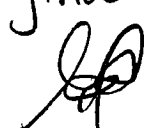
Original  

CUSTOM PRODUCTS CORP  
P.O. BOX 54091  
JACKSON, MS 39288-4091

**DOUGLAS COUNTY, KANSAS**

\*\*\*\*\*

FY 2014

SPECIFICATIONS AND CONTRACT DOCUMENTS

FOR

**SIGNS AND ACCESSORIES**

**BID NO. 14-F-0002**

\*\*\*\*\*

**DOUGLAS COUNTY, KANSAS**

**SPECIFICATIONS AND CONTRACT DOCUMENTS**

**FOR**

**PUBLIC WORKS DEPARTMENT**

**SIGNS AND ACCESSORIES**

**BID NO. 14-F-0002**

**BY**

**THE DOUGLAS COUNTY COMMISSIONERS**

**Mike Gaughan**  
Member

**Jim Flory**  
Member

**Nancy Thellman**  
Chairman

**Jamie Shew**  
County Clerk

**Keith A. Browning, P.E.**  
Director of Public Works



DOUGLAS COUNTY DEPARTMENT OF PUBLIC WORKS

BID NO. 14-F-0002

**NOTICE TO BIDDERS**

Notice is hereby given that sealed bids for the purchase of SIGNS AND ACCESSORIES, by the Douglas County Public Works Department, will be received in the office of the Douglas County Clerk, 1100 Massachusetts, Courthouse, Lawrence, Kansas, 66044 until 3:15 P.M., Tuesday, April 1, 2014, then publicly opened in the office of the Douglas County Clerk.

Bids must be submitted on forms provided by either the Douglas County Public Works Department, 1242 Massachusetts Street, Lawrence, Kansas or on the Internet at [www.demandstar.com](http://www.demandstar.com). The bids shall be submitted in sealed envelopes, addressed to the Office of the County Clerk, Courthouse, 1100 Massachusetts Street, Lawrence, Kansas 66044, upon which is clearly written or printed "Signs and Accessories", along with the name and address of the bidder. Any bid received by the Office of the County Clerk after the closing date and time will be returned unopened. Faxed bids will not be accepted. Douglas County is not responsible for the lost or misdirected bids, whether lost or misdirected by the postal or courier service of the bidder or the Douglas County mail room.

The awarded bidder shall agree to offer the prices and the terms and conditions herein to other government agencies who wish to participate in a cooperative purchase program with Douglas County. Other agencies will be responsible for entering into separate agreements with the awarded bidder and for all payments thereunder.

The Douglas County Department of Public Works reserves the right to reject any or all bids, or portions of bids, waive technicalities, and to purchase the items, which in the opinion of the Board, are best suited for the use intended.

Dated: March 10, 2014

DEPARTMENT OF PUBLIC WORKS  
DOUGLAS COUNTY, KANSAS  
Keith A. Browning, P.E.  
Director of Public Works

Published: Thursday, March 13, 2014  
Sunday, March 16, 2014

cc: Lawrence Journal World  
Board of County Commissioners  
County Clerk  
County Administrator  
County Shop  
Public Works Accounting  
Purchasing Department  
File

## DOUGLAS COUNTY PUBLIC WORKS DEPARTMENT

### Bid No. 14-F-0002 Signs and Accessories FY 2014

#### Instructions to Bidders

1. It is the intent of Douglas County to purchase the various Signs and Accessories listed in this brochure.
2. Proposals must be submitted on forms provided by either the Douglas County Public Works Department, 1242 Massachusetts Street, Lawrence, Kansas or Demand Star @ www.demandstar.com. Specifications and bid requirements are included in these documents. The proposal must be left intact and will be the only form accepted as a bid by the Board of County Commissioners.
3. Bidders shall show unit prices for each item listed, shall extend all unit prices and total all extensions. All prices shall be F.O.B. Lawrence, Kansas. The County is not subject to City or State Sales Tax.
4. The Devices specified shall conform to the Manual on Uniform Traffic Control Devices, latest edition, as approved by the Federal Highway Administrator as part of the National Standard for all Highways, unless otherwise indicated in the specifications.
5. Bidders shall specify delivery date. Delivery date will be considered, as well as total price, in the selection of the successful bidder. Liquidated damages in the amount of 1% per day of the total bid price of items not received by the specified delivery date will be charged.
6. **The supplier must notify Douglas County 48 hours prior to delivery.** Douglas County reserves the right to refuse any shipment if proper advance notice is not received.
7. The back face of all finished signs shall be permanently marked with the producers name and year of manufacture. The size of the identification shall be no larger than 4" X 2", unless previously approved by the County Engineer.
8. The awarded bidder shall agree to offer the prices and the terms and conditions offered herein to other governmental agencies who wish to participate in a cooperative purchase program with Douglas County. All other agencies contracting with any vendor shall be responsible for entering into separate agreements and for all payments thereunder.
9. Bids must be sealed and received in the Douglas County Clerk's Office, Douglas County Courthouse, 1100 Massachusetts, Lawrence, Kansas 66044, prior to 3:15 P.M., Tuesday, April 1, 2014. Faxed bids will not be accepted. The County is not responsible for lost or misdirected bids, whether lost or misdirected by the postal or courier service of the bidder or the County mail room. Any bids received after the time specified will be returned unopened.
10. The County reserves the right to reject any or all bids or waive technicalities and to purchase the items which, in the opinion of the Board of County Commissioners, are best suited to the work for which they are intended. **The award will be made to the lowest and best bidder for each group of items specified (finished signs, fluorescent signs, cut out lettering, steel posts and telespar posts). Miscellaneous items will be awarded on an item by item basis.**

### Instructions to Bidders (continued)

11. All sheeting used on sign faces shall be TYPE IV High Intensity Prismatic Grade or TYPE VIII or better for Fluorescent Orange, Yellow and Yellow/Green sheeting meeting the requirements stated in Section 2201, "Retroreflective Sheeting", of the KDOT Standard Specifications, 2007 Edition, unless otherwise indicated in the bid documents. A copy of this specification is attached to this proposal, or may be viewed at <http://www.ksdot.org/burconsmain/specprov/2007/2201.pdf>. A list of pre-qualified materials can be found at <http://www.ksdot.org/burmatres/pql/default.asp>.
12. The chip and seal markers shall meet the requirements stated in Special Provision 07-22004 (Temporary Raised Pavement Markers) in Section 2200, "Reflective Materials and Accessory Items", of the KDOT Standard Specifications, 2007 Edition. A copy of this Special Provision is attached to this proposal, or may be viewed at <http://www.ksdot.org/burconsmain/specprov/2007/pdf/07-22004.pdf>.
13. All sign blanks shall be a minimum of .080 gauge aluminum (except those greater than 36" in any dimension, which shall be .10 gauge), unless otherwise specified.

STANDARD TERMS AND CONDITIONS  
DOUGLAS COUNTY, KANSAS

1. SCOPE: The following terms and conditions shall prevail unless otherwise modified by Douglas County within this bid document. Douglas County reserves the right to accept or reject any or all bids received, waive technicalities, and to purchase the products, which in the opinion of the Board of County Commissioners, is best suited to the work for which it is intended.
  
2. DEFINITIONS AS USED HEREIN:
  - a. The term "bid request" means a solicitation of a formal sealed bid.
  - b. The term "bid" means the price offered by the bidder.
  - c. The term "bidder" means the offer or vendor.
  - d. The term "County" means Douglas County, Kansas.
  - e. The term "Board of County Commissioners or "BOCC" means the governing body of Douglas County, Kansas.
  - f. The term "awarded bidder" means any bidder awarded a contract pursuant to its bid.
  
3. COMPLETING BID: Bids must be submitted only on the forms (or reproductions thereof) provided in this document. All information must be legible. Any and all corrections and/or erasures must be initialed. Each bid sheet must be signed by the authorized bidder and all required information must be provided.
  
4. CONFIDENTIALITY OF BID INFORMATION: Each bid must be sealed and submitted in an envelope clearly marked "SIGNS AND ACCESSORIES" to provide confidentiality of the bid information prior to the bid opening. Supporting documents and/or descriptive literature may be submitted with the bid. Do not indicate bid prices on literature.

All bids and supporting bid documents become public information after the bid opening and are available for public inspection by the general public in accordance with the Kansas Open Records Act.
  
5. ACCURACY OF BID: Each bid is publicly opened in the presence of the Douglas County Clerk. It is required that any and all information presented is accurate and/or will be that by which the bidder will perform if awarded the contract. If there is a discrepancy between the unit price and extended total, the unit price will prevail.
  
6. SUBMISSION OF BID: Bids must be sealed and received in the Douglas County Clerk's Office, Douglas County Courthouse, 1100 Massachusetts, Lawrence, Kansas 66044, prior to 3:15 P.M., Tuesday, April 1, 2014. Faxed bids will not be accepted. The County is not responsible for lost or misdirected bids, whether lost or misdirected by the postal or courier service of the bidder or the County mail room.
  
7. ADDENDA: All changes in connection with this bid will be issued in the form of a written addendum. Signed acknowledgment of receipt of each addendum must be submitted with the bid.

STANDARD TERMS AND CONDITIONS (continued)

8. LATE BIDS, CHANGES OR WITHDRAWALS: Bids received after the deadline designated in this bid document shall not be considered and shall be returned unopened.

Bids may be changed or withdrawn prior to the bid opening. All such transactions must be submitted in writing and received by the County Clerk's Office prior to the bid deadline. Changes or withdrawals may be made after the bid deadline only with the approval of the Board of County Commissioners. After bid opening, no changes in bid prices or other provisions of bids prejudicial to the interest of the County or fair competition shall be permitted.

9. BIDS BINDING: All bids submitted shall be binding upon the bidder if accepted by the County within fifteen (15) calendar days after the bid opening.

10. EQUIVALENT BIDS: When brand or trade names are used in the bid invitation, it is for the purpose of item identification and to establish standards for quality, style and features. Bids on equivalent items of substantially the same quality, style and features are invited unless items are marked "No Substitute." Equivalent bids must be accompanied by descriptive literature and/or specifications to receive consideration. Demonstrations and/or samples may be required and shall be supplied at no charge to the County.

11. NEW MATERIALS, SUPPLIES OR EQUIPMENT: Unless otherwise specified, all materials, supplies or equipment offered by a bidder shall be new, unused, of recent manufacture, first class in every respect and suitable for their intended purpose. All equipment shall be assembled, and ready for operation when delivered.

12. WARRANTY: Supplies or services furnished as a result of this bid shall be covered by the most favorable commercial warranties, expressed or implied, that the bidder and/or manufacturer gives to any customer. The rights and remedies provided herein are in addition to and do not limit any rights afforded to the County by any other clause of this bid. The County reserves the right to request from bidders a separate manufacturer certification of all statements made in the proposal.

13. METHOD OF AWARD AND NOTIFICATION: Bids will be evaluated and the award made to the lowest and best, responsive and responsible bidder(s) whose bid conforms to the specifications and whose bid is considered to be the best value in the opinion of the Board of County Commissioners.

The County reserves the right to accept or reject any or all bids and any part of a bid and to waive informalities, technical defects, and minor irregularities in bids received. **The award will be made to the lowest and best bidder for each group of items specified (finished signs, fluorescent signs, cut out lettering, steel posts and telespar posts). Miscellaneous items will be awarded on an item by item basis.**

The signed bid shall be considered an offer on the part of the bidder; such offer shall be deemed accepted upon issuance by the County of a Purchase Order or other contractual document.

STANDARD TERMS AND CONDITIONS (continued)

14. DELIVERY TERMS: All deliveries shall be F.O.B. Lawrence, Kansas and all freight charges shall be included in the bid price. Delivery date shall be considered as a cost factor in the determination of award.
15. DAMAGED AND/OR LATE SHIPMENTS: The County has no obligation to accept damaged shipments and reserves the right to return at the vendor's expense damaged merchandise even though the damage was not apparent or discovered until after receipt of the items. The Vendor is responsible to notify the Douglas County Department of Public Works of any late or delayed shipments. The County reserves the right to cancel all or any part of an order if the shipment is not made as promised.
16. CREDIT TERMS: Bidder shall indicate all discounts for full and/or prompt payment. Discounts offered shall be computed from date of receipt of correct invoice or receipt and acceptance of products, whichever is later.
17. SELLERS INVOICE: Invoices shall be prepared and submitted in at least two copies to the address shown on the Purchase Order or bid document. Separate invoices are required for each Purchase Order or bid document. Invoices shall contain the following information: Purchase order number and date, bid number, item number, description of supplies or services, sizes, unit of measure, quantity, unit price and extended totals.
18. TAX EXEMPT: The County and its agencies are exempt from State and local sales taxes by K.S.A. 79-3606, as amended. Situs of all transactions under the order(s) that shall be derived from this request shall be deemed to have been accomplished within the State of Kansas.
19. SAFETY: All practices, materials, supplies and equipment shall comply with the Federal Occupational Safety and Health Act, as well as any pertinent Federal, state and/or local safety or environmental codes.
20. DISCLAIMER OF LIABILITY: The County, or any of its agencies, will not hold harmless or indemnify any bidder for any liability whatsoever.
21. HOLD HARMLESS: The awarded bidder agrees to protect, defend, indemnify and hold the Board of County Commissioners, its officers, employees and agents free and harmless from and against any and all losses, penalties, damages, settlements, costs, charges, professional fees or other expenses or liabilities of every kind and character arising out of or relating to any and all claims, liens, demands, obligations, actions, proceedings or causes of action of every kind and character in connection with or arising directly or indirectly out of this agreement and/or the performance hereof. Without limiting the generality of the foregoing, and all such claims, etc., relating to personal injury, infringement of any patent, trademark, copyright (or application for any thereof) or of any other tangible or intangible personal or property right, or actual or alleged violation of any applicable statute, ordinance, administrative order, rule or regulation, or decree of any court, shall be included in the indemnity hereunder. The awarded bidder further agrees to investigate, handle, respond to, provide defense for and defend any such claims, etc., at his/her sole expense and agrees to bear all other costs and expenses related thereto, even if such claim is groundless, false or fraudulent.

STANDARD TERMS AND CONDITIONS (continued)

22. LAW GOVERNING: All contractual agreements shall be subject to, governed by, and construed according to the laws of the State of Kansas.
23. ANTI-DISCRIMINATION CLAUSE: No bidder on this request shall in any way, directly or indirectly, discriminate against any person because of age, race, color, handicap, sex, national origin, or religious creed.

BID  
For  
VARIOUS SIGNS AND ACCESSORIES

**Bid No. 14-F-0002**

Price shall include delivery to the Douglas County Shop, 23rd and Santa Fe Tracks, 711 E 23<sup>rd</sup> St., Lawrence, Kansas.

The Devices specified shall conform to the Manual on Uniform Traffic Control Devices, latest edition, as approved by the Federal Highway Administrator as part of the National Standard for all Highways unless otherwise indicated in the Specifications and Contract Documents.

The Douglas County Public Works 2014 Combined Sign Bid attached hereto is incorporated herein by this reference and is the undersigned bidders bid.

Bids must be returned to the Office of the Douglas County Clerk no later than, 3:15 P.M., Tuesday, April 1, 2014.

**The bidder shall notify Douglas County 48 hours prior to delivery.**

Date available for delivery: 21 Days / 60-90 Days for Posts.

Bidder: Custom Products Corporation

By: Alex Hoegge

Recommended for Approval:

DOUGLAS COUNTY, KANSAS  
Board of County Commissioners

Keith A. Browning  
Keith A. Browning, P.E.  
Director of Public Works

Nancy Thellman, Chairman

Mike Gaughan, Member

Jim Flory, Member

Date



SECTION 2201

RETROREFLECTIVE SHEETING

2201.1 DESCRIPTION

This specification covers Type I and all Types of High Intensity retroreflective sheeting. This includes both non-exposed glass bead lens and microprismatic sheeting.

2201.2 REQUIREMENTS

a. **General.** Provide retroreflective sheeting that complies with ASTM D 4956 (latest revision) except for the color limits as specified in subsection 2201.2b. The type to be provided will be shown in the Contract Documents. Types and classes are as defined in ASTM D 4956.

b. **Color.** The colors of the retroreflective sheeting are white, yellow, red, orange, green, blue, brown, fluorescent orange, fluorescent yellow, and fluorescent yellow-green. Provide colors that comply with the chromaticity limits as shown in TABLE 2201-1 for both Type I and Type III sheeting and TABLE 2201-2 for all other Types of High Intensity sheeting (Type IV through Type XI). Provide fluorescent colors that comply with the chromaticity limits in ASTM D 4956 (latest revision).

TABLE 2201-1: COLOR SPECIFICATION (Type I and Type III)								
COLOR	Chromaticity Coordinates							
	1		2		3		4	
	x	y	x	y	x	y	x	y
White	0.310	0.313	0.338	0.342	0.325	0.355	0.300	0.327
Yellow	0.496	0.503	0.545	0.454	0.505	0.433	0.460	0.474
Red	0.574	0.337	0.665	0.345	0.708	0.292	0.613	0.297
Orange	0.558	0.352	0.636	0.364	0.570	0.429	0.506	0.404
Green	0.130	0.387	0.180	0.410	0.140	0.521	0.098	0.490
Blue	0.138	0.065	0.112	0.135	0.160	0.170	0.176	0.120
Brown	0.430	0.340	0.610	0.390	0.550	0.450	0.430	0.390

TABLE 2201-2: COLOR SPECIFICATION (Type IV - Type XI)								
COLOR	Chromaticity Coordinates							
	1		2		3		4	
	x	y	x	y	x	y	x	y
White	0.310	0.313	0.328	0.331	0.316	0.345	0.300	0.327
Yellow	0.515	0.484	0.545	0.454	0.505	0.433	0.475	0.460
Red	0.586	0.324	0.664	0.336	0.708	0.292	0.613	0.297
Orange	0.558	0.352	0.636	0.364	0.570	0.429	0.506	0.404
Green	0.130	0.387	0.180	0.410	0.155	0.478	0.107	0.457
Blue	0.138	0.065	0.112	0.135	0.160	0.170	0.176	0.120
Brown	0.430	0.340	0.610	0.390	0.550	0.450	0.430	0.390

c. **Conformable Retroreflective Sheeting.** Provide High Intensity retroreflective sheeting that has a conformable aluminum foil backing with an aggressive pressure sensitive adhesive. This material is designed for application to moderately rough or porous metal, wood or masonry surfaces. Provide material that complies with ASTM D 4956 (latest revision) with the following exceptions and additions:

- (1) Conformable aluminum backing thickness - 0.005 inches to 0.010 inches.
- (2) Follow all manufacturers' recommendations for application procedures and temperatures.

2201.3 MANUFACTURER WARRANTY

The following warranty conditions apply only to the retroreflective sheeting manufacturer. Provide a product warranty for a minimum period of 10 years on all Types of High Intensity retroreflective sheeting, for placement on permanent signing. Failure to comply with this warranty may be cause for removal from the prequalified list.

The High Intensity retroreflective sheeting warranty must comply with the following requirements and obligations:

- Certification: Submit with each lot or shipment, a certification which states that the material supplied is subject to and complies with the requirements. Include in the certification, the manufacturer's office, address, phone number and the contact for potential claims under the provisions of this warranty. Provide documentation as to which signs were fabricated from each lot.
- Field Performance: Field Performance applies to retroreflective sheeting applied to sign blank materials or overlaid on existing signs. The field performance obligation period begins with the date of erection. The sheeting is considered unsatisfactory if it has deteriorated due to natural causes to the extent that the sign is ineffective for its intended purpose when viewed from a moving vehicle under normal day and night driving conditions or shows any of the following defects:
  - Cracking discernible with the unaided eye from a driver's position at a distance of 50 feet or greater from the sign;
  - More than 25% loss of specular gloss and cracking, scaling, pitting, orange peel, delamination, edge lifting or curling;
  - Peeling in excess of 3/8 inch;
  - Shrinkage in excess of 3/16 inch total per yard of sheeting width;
  - Fading or loss or color to the extent that retroreflective sheeting color fails to comply with the subsection 2201.2b., or;
  - Loss of retroreflectivity reducing the coefficient of retroreflection as measured by a retroreflectometer to less than the minimum specified in TABLE 2201-3 at 0.2° observation and -4° entrance angles. Make all measurements after cleaning the sign.

<b>TABLE 2201-3: MINIMUM COEFFICIENT OF RETROREFLECTION CANDELAS PER SQUARE METER PER LUX</b>	
Sheeting Color	Min. Coefficient
White	200
Yellow	136
Green	36
Red	36
Blue	16
Brown	9

**Defective Material Replacement:** When traffic signs with High Intensity sheeting fail to comply with the field performance requirements, re-sheet or replace the signs at no cost to the Douglas County for materials and labor. Employ a contractor qualified by the KDOT to perform signing work. Install highway signs, as shown in the Contract Documents and the M.U.T.C.D. (latest edition) and provide proper traffic control.

Replace all defective material within 60 days after written notification by Douglas County. Signs not corrected within 60 days, will be removed and replaced by Douglas County. Signs removed by Douglas County will be placed in storage for inspections by the manufacturer, and the manufacturer will be billed for all costs of replacement of the sheeting.

When more than 25% of the signs within a lot fail to comply with the requirements, replace all signs made from that lot.

#### **2201.4 PREQUALIFICATION**

Manufacturers desiring to provide material under this specification are to submit prequalification samples of each type, class and color covered by this specification which they wish to prequalify. Each sample consists of 3 pieces 24 inches square.

Forward the prequalification samples to the Engineer of Tests, Materials and Research Center, 2300 Van Buren, Topeka, KS 66611. Samples will be tested for compliance with all requirements of this specification. Each Manufacturer will be notified of the test results.

If the prequalification samples of retroreflective sheeting comply with this specification, the product will be placed on a list of prequalified products maintained by the Bureau of Materials and Research. No retroreflective sheeting will be used on KDOT projects unless it has been prequalified. Manufacturers will be required to requalify at intervals determined by the Engineer of Tests.

Testing and evaluation by KDOT may be waived if complete testing has been performed on the identical product by AASHTO National Transportation Product Evaluation Program (NTPEP). Forward an official copy of the test report along with evidence that the product referenced is identical to that submitted for prequalification, to the Engineer of Tests for evaluation.

## **2201.5 METHODS OF TESTS**

All tests will be conducted in accordance with ASTM D 4956 with the exception of artificial weathering. Artificial weathering will be conducted according to ASTM G 155, Cycle 1, with the following additions and exceptions:

- At the end of each 20 hour cycle, the panels will be placed in a cold cabinet at approximately 0°F for one hour. After removal from the cold cabinet, panels will be returned to the weatherometer to await the start of the next cycle.
- Water used in the weatherometer will be city water softened to a total hardness content of less than 5 parts per million expressed as calcium carbonate.

## **2201.6 BASIS OF ACCEPTANCE**

### **a. Permanent Sheeting.**

(1) Prequalification as required by **subsection 2201.4**.

(2) Satisfactory results of tests conducted at MRC. Each lot of sheeting will be sampled at destination by a representative of the KDOT and will be subjected to a visual examination and tested for physical properties as necessary to verify that the sheeting complies with this specification.

(3) Receipt of the warranty certification as specified in **subsection 2201.3** by the County Engineer.

**b. Temporary Sheeting.** Retroreflective sheeting used to manufacture temporary traffic control signs will be accepted on the basis of a certification prepared by the contractor stating that the retroreflective sheeting used to manufacture the signs was prequalified under this specification, and visual inspection by the Engineer for condition and other requirements.

**KANSAS DEPARTMENT OF TRANSPORTATION  
SPECIAL PROVISION TO THE  
STANDARD SPECIFICATIONS, EDITION 2007**

Add a new SECTION in DIVISION 2200:

**TEMPORARY RAISED PAVEMENT MARKERS**

**1.0 DESCRIPTION**

This specification covers temporary raised pavement markers for lane marking and delineation. This includes both Flexible and Rigid (Types I and II) markers for use on both Portland cement concrete and asphalt surfaces.

**2.0 REQUIREMENTS**

**a. General.**

(1) Provide temporary reflective markers as shown in the Contract Documents. The markers shall be readily visible at night, from a minimum of 300 feet, when viewed with high beam automobile headlamps. Prior to use, markers must be approved by the Engineer. The marker shall be the same color as the reflective elements. All markers shall be capable of sustaining 2000 direct wheel-over impacts at 60 mph without losing adhesion to the roadway or sustaining damage to the marker body.

(2) Provide Flexible temporary raised pavement markers which consist of an L-shaped flexible polyurethane body with prismatic reflective sheeting on both faces. The reflective sheeting shall be a minimum of 1 square inch spread over the 4" wide marker. The markers shall have minimum dimensions of 4 inches wide x 2 inches high with a 1 inch wide base leg. Thickness of the body shall be a minimum of 0.06 inches. The marker shall have an affixed pressure sensitive adhesive, protected by a release paper, for application to the pavement surface. Attach a clear flexible plastic cover to the vertical section of the marker to protect the reflective material during surfacing operations. The cover shall withstand the work and be easily removed after the operation. The markers shall not cause any damage to the automobile.

(3) Provide Rigid (Type I) temporary raised pavement markers constructed of traffic bearing high impact plastic with prismatic reflective faces. The base of the markers shall have minimum dimensions of 2.5 inches wide, 4 inches long and 0.4 inches high. The base of the marker shall be flat. Markers shall be reflectorized with one or more reflective faces on each side using either an acrylic retroreflector, or retroreflective sheeting. Each face shall contain a minimum of 0.38 square inches of reflective surface. The adhesive used shall not stain the pavement and will allow the markers to be easily removed without damage to the roadway surface. If the marker is self adhesive, it shall be pre-coated with an affixed pressure sensitive adhesive, protected by a release paper.

(4) Provide Rigid (Type II) or brick markers constructed of traffic bearing high impact plastic with prismatic reflective faces. The marker shall have minimum dimensions of 2.5 inches high, 7.5 inches wide and 13 inches long. The base of the marker shall be flat. Markers shall be reflectorized with two or more reflective faces on each side using either an acrylic retroreflector, or retroreflective sheeting. Each face shall contain a minimum of 3.75 square inches of reflective surface. The adhesive used will allow the markers to be removed without damage to the roadway surface. If the marker is self adhesive, it shall be pre-coated with an affixed pressure sensitive adhesive, protected by a release paper.

**b. Retroreflectivity.** Provide markers in white or yellow which comply with the minimum requirements shown in TABLE 1:

<b>TABLE 1: RETROREFLECTIVITY REQUIREMENTS</b>	
<b>Color</b>	<b>Millicandelas/sq m/lux (min.)<sup>a</sup> (measured at 0.2° observation angle and 0° entrance angle)</b>
White	3.0
Yellow	1.8

<sup>a</sup> Flexible markers must meet these requirements before and after durability testing

c. **Color.** Markers shall be white or yellow in color, solid throughout, and match the color of the lane line on which the marker will be placed under both daylight and nighttime conditions.

d. **Durability.** Flexible markers, as defined in subsection 2.0a.(2), must withstand 2000 revolutions on a small-wheel circular track. 12 markers of each color will be tested. No more than 3 markers shall move from their original position during testing.

### 3.0 TEST METHODS

a. **Retroreflectivity.** Test in accordance with ASTM E 809.

b. **Durability.** Test in accordance with ASTM E 660, with the following variations:

(1) Mount two opposite wheels with 11 x 6.00 x 5 nylon smooth non-pattern tread tires with a total load of 50 pounds on each tire. Maintain tire pressure at 25 psi. Mount the wheels perpendicular to the specimens and toe out 2° to produce a slight abrading action.

(2) Apply markers, according to the manufacturer's recommendations, to 6 inch diameter dense grade asphalt concrete cores, which have been compacted at 3000 psi for 2 minutes.

### 4.0 PREQUALIFICATION

Manufacturers wishing to supply markers to KDOT projects must have their product tested by the AASHTO National Transportation Product Evaluation Program (NTPEP). Submit 12 flexible markers or 2 rigid markers of each color for which prequalification is requested, and an official copy of the NTPEP test report to the Engineer of Tests, Materials and Research Center, 2300 Van Buren, Topeka, KS 66611. Include evidence that the product offered is identical to that described in the test report, and information regarding the recommended adhesive, if any is required. Prequalification will be based on satisfactory compliance of NTPEP results and laboratory testing with subsection 2.0.

### 5.0 BASIS OF ACCEPTANCE

Prequalification as required by subsection 4.0.

Receipt and approval of a Type C certification as specified in DIVISION 2600.

Visual inspection for condition and dimensional requirements.

Custom Products Corporation

DOUGLAS COUNTY PUBLIC WORKS  
2014 COMBINED SIGN BID

3/5/2014

FINISHED SIGNS

MUTCD #	SIZE	DESCRIPTION	COLOR	SHEETING	REMARKS	# TO ORDER	UNIT COST	EXTENDED COST
M1-6	24 X 24	DOUGLAS COUNTY	YELLOW/BLUE	TY IV, H/I PRISM.	NO ROUTE NUMBER	10	\$ 20.71	\$ 207.10-
M1-6	24 X 24	DOUGLAS COUNTY 1	YELLOW/BLUE	TY IV, H/I PRISM.	ROUTE MARKER	4	\$ 23.00	\$ 92.00-
M1-6	24 X 24	DOUGLAS COUNTY 1S	YELLOW/BLUE	TY IV, H/I PRISM.	ROUTE MARKER	5	\$ 23.00	\$ 115.00-
M1-6	24 X 24	DOUGLAS COUNTY 1W	YELLOW/BLUE	TY IV, H/I PRISM.	ROUTE MARKER	5	\$ 23.00	\$ 115.00-
M1-6	24 X 24	DOUGLAS COUNTY 1E	YELLOW/BLUE	TY IV, H/I PRISM.	ROUTE MARKER	5	\$ 23.00	\$ 115.00-
M1-6	24 X 24	DOUGLAS COUNTY 2	YELLOW/BLUE	TY IV, H/I PRISM.	ROUTE MARKER	5	\$ 23.00	\$ 115.00-
M1-6	24 X 24	DOUGLAS COUNTY 3	YELLOW/BLUE	TY IV, H/I PRISM.	ROUTE MARKER	5	\$ 23.00	\$ 115.00-
M1-6	24 X 24	DOUGLAS COUNTY 4	YELLOW/BLUE	TY IV, H/I PRISM.	ROUTE MARKER	4	\$ 23.00	\$ 92.00-
M1-6	24 X 24	DOUGLAS COUNTY 6	YELLOW/BLUE	TY IV, H/I PRISM.	ROUTE MARKER	10	\$ 23.00	\$ 230.00-
M1-6	24 X 24	DOUGLAS COUNTY 438	YELLOW/BLUE	TY IV, H/I PRISM.	ROUTE MARKER	7	\$ 23.00	\$ 161.00-
M1-6	24 X 24	DOUGLAS COUNTY 442	YELLOW/BLUE	TY IV, H/I PRISM.	ROUTE MARKER	5	\$ 23.00	\$ 115.00-
M1-6	24 X 24	DOUGLAS COUNTY 460	YELLOW/BLUE	TY IV, H/I PRISM.	ROUTE MARKER	10	\$ 23.00	\$ 230.00-
M1-6	24 X 24	DOUGLAS COUNTY 1023	YELLOW/BLUE	TY IV, H/I PRISM.	ROUTE MARKER	10	\$ 23.00	\$ 230.00-
M1-6	24 X 24	DOUGLAS COUNTY 1029	YELLOW/BLUE	TY IV, H/I PRISM.	ROUTE MARKER	10	\$ 23.00	\$ 230.00-
M1-6	24 X 24	DOUGLAS COUNTY 1039	YELLOW/BLUE	TY IV, H/I PRISM.	ROUTE MARKER	7	\$ 23.00	\$ 161.00-
M4-6	24 X 12	"END" - AUXILIARY SIGN	BLACK/WHITE	TY IV, H/I PRISM.		5	\$ 8.18	\$ 40.90-
M6-1	21 X 15	DIRECTIONAL SIGN	BLACK/WHITE	TY IV, H/I PRISM.		10	\$ 8.97	\$ 89.70-
OM2-2V	6 X 12	TYPE 2 OBJECT MARKER	YELLOW	TY IV, H/I PRISM.		400	\$ 2.51	\$ 1,004.00-
OM2-2V	6 X 12	TYPE 2 OBJECT MARKER	WHITE	TY IV, H/I PRISM.		50	\$ 2.51	\$ 125.50-
OM3-L	12 X 36	OBJECT MARKER TYPE III - LEFT. 100	BLACK/YELLOW	TY IV, H/I PRISM.	SEE PLAN DETAILS	254	\$ 15.39	\$ 3,909.06-
OM3-R	12 X 36	OBJECT MARKER TYPE III - RIGHT. 100	BLACK/YELLOW	TY IV, H/I PRISM.	SEE PLAN DETAILS	250	\$ 15.39	\$ 3,847.50-
OM4-3	18 X 18	END OF ROAD MARKER	RED	TY IV, H/I PRISM.		24	\$ 8.84	\$ 212.16-
R1-1	30 X 30	STOP SIGN	WHITE/RED	TY IV, H/I PRISM.		20	\$ 21.16	\$ 423.20-
R1-2	30 X 30 X 30	YIELD	WHITE/RED	TY IV, H/I PRISM.		1	\$ 12.21	\$ 12.21-
R1-3P	18 X 6	ALL WAY	WHITE/RED	TY IV, H/I PRISM.		8	\$ 3.85	\$ 30.80-
R2-1	24 X 30	"SPEED LIMIT"	BLACK/WHITE	TY IV, H/I PRISM.	NO SPEED LIMIT NUMBER	7	\$ 18.96	\$ 132.72-
R2-1-25	24 X 30	"SPEED LIMIT 25"	BLACK/WHITE	TY IV, H/I PRISM.		4	\$ 18.96	\$ 75.84-
R2-1-40	24 X 30	"SPEED LIMIT 40"	BLACK/WHITE	TY IV, H/I PRISM.		5	\$ 18.96	\$ 94.80-
R2-1-55	24 X 30	"SPEED LIMIT 55"	BLACK/WHITE	TY IV, H/I PRISM.		20	\$ 18.96	\$ 379.20-
R5-1	30 X 30	"DO NOT ENTER"	WHITE/RED	TY IV, H/I PRISM.		2	\$ 23.00	\$ 46.00-
R7-1	12 X 18	NO PARKING ←	WHITE/RED	TY IV, H/I PRISM.	DOUBLE ARROW BELOW "NO PARKING"	5	\$ 6.05	\$ 30.25-
R7-1	18 x 24	NO PARKING ↔	WHITE/RED	TY IV, H/I PRISM.	DOUBLE ARROW BELOW "NO PARKING"	4	\$ 11.43	\$ 45.72-
R7-1L	12 x 18	NO PARKING ←	WHITE/RED	TY IV, H/I PRISM.	LEFT ARROW BELOW "NO PARKING"	4	\$ 6.05	\$ 24.20-
R7-1L	18 x 24	NO PARKING ←	WHITE/RED	TY IV, H/I PRISM.	LEFT ARROW BELOW "NO PARKING"	7	\$ 11.43	\$ 80.01-
R7-1R	12 x 18	NO PARKING →	WHITE/RED	TY IV, H/I PRISM.	RIGHT ARROW BELOW "NO PARKING"	5	\$ 6.05	\$ 30.25-
R7-1R	18 x 24	NO PARKING →	WHITE/RED	TY IV, H/I PRISM.	RIGHT ARROW BELOW "NO PARKING"	2	\$ 11.43	\$ 22.86-
R11-2	48 X 30	"ROAD CLOSED" .100	BLACK/WHITE	TY IV, H/I PRISM.	2 LINES	7	\$ 51.06	\$ 357.42
R11-3a	60 X 30	"ROAD CLOSED" MILES AHEAD LOCAL TRAFFIC ONLY" .100	BLACK/WHITE	TY IV, H/I PRISM.	3 LINES	4	\$ 62.01	\$ 248.04
R12-1	24 X 30	"WEIGHT LIMIT TONS"	BLACK/WHITE	TY IV, H/I PRISM.		5	\$ 18.90	\$ 94.50-
R12-5	24 X 36	"WEIGHT LIMIT TONS" .100	BLACK/WHITE	TY IV, H/I PRISM.	3 TIER W/ NO DISPLAYED # - "T" ONLY	10	\$ 29.99	\$ 299.90-

36" (4)  
100 gauge  
gauge  
36" (4)  
100

Custom Products Corporation

SUBTOTAL FINISHED SIGNS

\$ 1,381.07

Bid Submitted By:

*Alex Hoegs*

Authorized Signature:

*[Signature]*

\$ 13,980.14

100 gauge

DOUGLAS COUNTY PUBLIC WORKS  
2014 COMBINED SIGN BID

748

3/5/2014

Custom Products Corporation

FINISHED SIGNS (CONTINUED)

MUTCD #	SIZE	DESCRIPTION	COLOR	SHEETING	REMARKS	# TO ORDER	UNIT COST	EXTENDED COST
W1-1L	30 X 30	LEFT TURN ARROW	BLACK/YELLOW	TY IV, H/I PRISM.		4	\$ 23.00	\$ 92.00-
W1-1L	48 X 48	LEFT TURN ARROW .100	BLACK/YELLOW	TY IV, H/I PRISM.		2	\$ 81.20	\$ 162.40-
W1-1R	36 X 36	RIGHT TURN ARROW .100	BLACK/YELLOW	TY IV, H/I PRISM.		4	\$ 44.74	\$ 178.96-
W1-1R	48 X 48	RIGHT TURN ARROW .100	BLACK/YELLOW	TY IV, H/I PRISM.		3	\$ 81.20	\$ 243.60-
W1-2L	30 X 30	CURVE SIGN - LEFT	BLACK/YELLOW	TY IV, H/I PRISM.		2	\$ 23.00	\$ 46.00-
W1-2L	36 X 36	CURVE SIGN - LEFT .100	BLACK/YELLOW	TY IV, H/I PRISM.		3	\$ 44.74	\$ 134.22-
W1-2L	48 X 48	CURVE SIGN - LEFT .100	BLACK/YELLOW	TY IV, H/I PRISM.		2	\$ 81.20	\$ 162.40-
W1-2R	30 X 30	CURVE SIGN - RIGHT	BLACK/YELLOW	TY IV, H/I PRISM.		5	\$ 23.00	\$ 115.00-
W1-2R	36 X 36	CURVE SIGN - RIGHT .100	BLACK/YELLOW	TY IV, H/I PRISM.		4	\$ 44.74	\$ 178.96-
W1-3R	30 X 30	REVERSE TURN SIGN - RIGHT	BLACK/YELLOW	TY IV, H/I PRISM.		1	\$ 23.00	\$ 23.00-
W1-6	36 X 18	ONE-DIRECTION LARGE ARROW .100	BLACK/YELLOW	TY IV, H/I PRISM.		4	\$ 23.06	\$ 92.24-
W1-6	48 X 24	ONE-DIRECTION LARGE ARROW .100	BLACK/YELLOW	TY IV, H/I PRISM.		3	\$ 40.07	\$ 120.21-
W1-7	36 X 18	TWO-DIRECTION LARGE ARROW .100	BLACK/YELLOW	TY IV, H/I PRISM.		3	\$ 23.06	\$ 69.18-
W1-7	48 X 24	TWO-DIRECTION LARGE ARROW .100	BLACK/YELLOW	TY IV, H/I PRISM.		5	\$ 40.07	\$ 200.35-
W1-8	18 X 24	CHEVRON ALIGNMENT SIGN	BLACK/YELLOW	TY IV, H/I PRISM.		60	\$ 11.43	\$ 685.80-
W2-4	30 X 30	T-INTERSECTION AHEAD	BLACK/YELLOW	TY IV, H/I PRISM.		3	\$ 23.00	\$ 69.00-
W3-5	36 X 36	REDUCE SPEED LIMIT AHEAD 30 .100	BL-WHITE/YELLOW	TY IV, H/I PRISM.		4	\$ 44.74	\$ 178.96-
W3-5	36 X 36	REDUCE SPEED LIMIT AHEAD 40 .100	BL-WHITE/YELLOW	TY IV, H/I PRISM.		5	\$ 44.74	\$ 223.70-
W8-6	30 X 30	TRUCK CROSSING	BLACK/YELLOW	TY IV, H/I PRISM.		4	\$ 23.00	\$ 92.00-
W8-17	30 X 30	SHOULDER DROP OFF (SYMBOL) .100	BLACK/YELLOW	TY IV, H/I PRISM.		7	\$ 23.00	\$ 161.00-
W10-1	36 DIA	GRADE CROSSING ADVANCE WARNING	BLACK/YELLOW	TY IV, H/I PRISM.	.100 (RAILROAD EMBLEM)	6	\$ 44.74	\$ 268.44-
W11-8	36 X 36	EMERGENCY VEHICLE .100	BLACK/YELLOW	TY IV, H/I PRISM.		5	\$ 44.74	\$ 223.70-
W11-8P	24 X 18	"FIRE STATION"	BLACK/YELLOW	TY IV, H/I PRISM.	TWO LINES	4	\$ 11.43	\$ 45.72-
W13-1P	18 X 18	"20 MPH"	BLACK/YELLOW	TY IV, H/I PRISM.		5	\$ 9.23	\$ 46.15-
W13-1P	18 X 18	"35 MPH"	BLACK/YELLOW	TY IV, H/I PRISM.		5	\$ 9.23	\$ 46.15-
W13-1P	24 X 24	"45 MPH"	BLACK/YELLOW	TY IV, H/I PRISM.		6	\$ 15.23	\$ 91.38-
W14-1	30 X 30	"DEAD END"	BLACK/YELLOW	TY IV, H/I PRISM.		5	\$ 23.00	\$ 115.00-
W14-2	30 X 30	"NO OUTLET"	BLACK/YELLOW	TY IV, H/I PRISM.	DIAMOND SHAPE	6	\$ 23.00	\$ 138.00-
W14-3	48 X 48 X 36	"NO PASSING ZONE" PENNANT .100	BLACK/YELLOW	TY IV, H/I PRISM.	2 HOLES FOR 1 POST MOUNT	20	\$ 31.75	\$ 635.00-
W16-2P	18 X 12	"500 FEET" PLAQUE	BLACK/YELLOW	TY IV, H/I PRISM.		12	\$ 6.05	\$ 72.60-
W20-3	30 X 30	ROAD CLOSED	BLACK/YELLOW	TY IV, H/I PRISM.		6	\$ 23.00	\$ 138.00-
N/A	30 X 30	"FLOOD AREA AHEAD"	BLACK/YELLOW	TY IV, H/I PRISM.	DIAMOND SHAPE	4	\$ 23.00	\$ 92.00-

Color \*  
Color \*

SUBTOTAL FINISHED SIGNS

\$ 5,141.12

TOTAL COST FINISHED SIGNS

\$ 19,121.26

Custom Products Corporation

Bid Submitted By:

Alex Hoey

Authorized Signature:

[Signature]

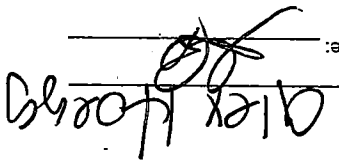
Authorized Signature:   
 Bid Submitted By: Alex Hoeggy

Custom Products Corporation

2014 COMBINED SIGN BID  
 DOUGLAS COUNTY PUBLIC WORKS

Custom Products Corporation

3/5/2014

FLUORESCENT SIGNS

MTC#	SIZE	DESCRIPTION	COLOR	SHEETING	REMARKS	# TO ORDER	UNIT	EXTENDED COST
M4-8	24 X 12	DETOUR	FLUORESCENT ORANGE	TY VIII OR BETTER		21		\$259.56
M4-8a	24 X 18	END DETOUR	FLUORESCENT ORANGE	TY VIII OR BETTER		4		\$71.84
M4-10R	48 X 18	DETOUR ARROW - LEFT	FLUORESCENT ORANGE	TY VIII OR BETTER		2		\$35.73
M4-10R	48 X 18	DETOUR ARROW - RIGHT	FLUORESCENT ORANGE	TY VIII OR BETTER		2		\$35.73
S3-1	30 X 30	SCHOOL BUS STOP AHEAD	FLUOR. YELLOW/GREEN	TY VIII OR BETTER		4		\$37.00
W8-1	36 X 36	BUMP	FLUORESCENT YELLOW	TY VIII OR BETTER		5		\$51.59
W8-4	36 X 36	SOFT SHOULDER	FLUORESCENT ORANGE	TY VIII OR BETTER		6		\$309.54
W8-8	36 X 36	ROUGH ROAD	FLUORESCENT ORANGE	TY VIII OR BETTER		1		\$51.59
W8-9	36 X 36	LOW SHOULDER	FLUORESCENT ORANGE	TY VIII OR BETTER		8		\$412.72
W8-11	36 X 36	UNEVEN LANES	FLUORESCENT ORANGE	TY VIII OR BETTER		8		\$412.72
W20-1	48 X 48	ROAD WORK AHEAD	FLUORESCENT ORANGE	TY VIII OR BETTER		21		\$1083.39
W20-1	48 X 48	ROAD WORK AHEAD	FLUORESCENT ORANGE	TY VIII OR BETTER		4		\$356.18
W20-2	48 X 48	DETOUR AHEAD	FLUORESCENT ORANGE	TY VIII OR BETTER		6		\$334.18
W20-2	48 X 48	DETOUR 500 FT	FLUORESCENT ORANGE	TY VIII OR BETTER		4		\$356.18
W20-3	48 X 48	"ROAD CLOSED"	FLUORESCENT ORANGE	TY VIII OR BETTER		4		\$356.18
W20-3	48 X 48	ROAD CLOSED 500 FT	FLUORESCENT ORANGE	TY VIII OR BETTER		4		\$356.18
W20-4	36 X 36	"ONE LANE ROAD AHEAD"	FLUORESCENT ORANGE	TY VIII OR BETTER		5		\$445.18
W20-4	36 X 36	"ONE LANE ROAD AHEAD"	FLUORESCENT ORANGE	TY VIII OR BETTER		14		\$722.26
W21-5	36 X 36	SHOULDER WORK	FLUORESCENT ORANGE	TY VIII OR BETTER		8		\$412.72
N/A	48 X 48	"TRUCKS TURNING"	FLUORESCENT ORANGE	TY VIII OR BETTER		4		\$375.84

TOTAL COST FLUORESCENT SIGNS

\$7,051.34

CUT OUT LETTERING

Series	SIZE	DESCRIPTION	COLOR	SHEETING	REMARKS	ORDER UNIT	EXTENDED COST
Series D	10"	NUMBER "1"	BLACK	TY IV, HI PRISM. PRESSURE SENSITIVE		1	\$19.96
Series D	10"	NUMBER "4"	BLACK	TY IV, HI PRISM. PRESSURE SENSITIVE		1	\$19.96
Series C	8"	NUMBER "4"	YELLOW	TY IV, HI PRISM. PRESSURE SENSITIVE		1	\$15.99

TOTAL COST CUT OUT LETTERING

\$54.91

\* NOTE: \* ASSUMING EACH PACKAGE CONTAINS 25 CHARACTERS



Custom Products Corporation

\* must order in increments of 25 for safety when shipping \*

*Handwritten initials/signature*

STEEL POSTS

LENGTH	WT./FT.	TYPE	REMARKS	# TO ORDER	UNIT COST	EXTENDED COST
7'	1.12#/FT.	STEEL DELINEATOR POST	GREEN ENAMEL	150	\$ 8.56	\$ 1284.00
7'	3#/FT.	STEEL	GREEN ENAMEL	150	\$ 16.08	\$ 2,412.00
8'	3#/FT.	STEEL	GREEN ENAMEL	60	\$ 20.27	\$ 1,216.20
10'	3#/FT.	STEEL	GREEN ENAMEL	20	\$ 24.21	\$ 484.20
* come in bundles of 25 * NOT COMPLIANT						\$ 5,396.40

TELESPAR POSTS

LENGTH	DIMENSION	TYPE	REMARKS	REMARKS	# TO ORDER	UNIT COST	EXTENDED COST
10'	1-1/2" SQUARE		14 GAUGE		10	\$ 27.41	\$ 274.10
10'	1-3/4" SQUARE		14 GAUGE		100	\$ 27.41	\$ 2,741.00
12'	1-3/4" SQUARE		14 GAUGE		75	\$ 33.89	\$ 2,541.75
3'	2" SQUARE		12 GAUGE	TUBULAR BASE	200	\$ 12.41	\$ 2,482.00
TOTAL COST TELESPAR POSTS							\$ 8,038.85

MISCELLANEOUS ITEMS  
AWARDED ON ITEM BY ITEM BASIS

SIZE	DESCRIPTION	REMARKS	# TO ORDER	UNIT COST	EXTENDED COST
4" X 50 YD	TEMP. PVMT MARKING TAPE;TY 2, YELLOW	FOILBACK (1 BOX @ 2 ROLLS EACH)	10	\$ 76.00	\$ 760.00

MUTCD #	SIZE	DESCRIPTION	COLOR	SHEETING	REMARKS	# TO ORDER	UNIT COST	EXTENDED COST
OM3-L	12 X 36	OM3 LEFT RE-FACE	BLACK/YELLOW	TY IV, H/I PRISM.	SHEETING ONLY - NO BLANK	10	\$ 5.11	\$ 51.10
OM3-R	12 X 36	OM3 RIGHT RE-FACE	BLACK/YELLOW	TY IV, H/I PRISM.	SHEETING ONLY - NO BLANK	10	\$ 5.11	\$ 51.10
TOTAL MISC. ITEMS								\$ 862.20

Custom Products Corporation

Bid Submitted By: Alyx Hoery  
Authorized Signature: [Signature]



Project	QUALITY ALERT SIGN
Request	SP180
Design/Drawn	LM
Checked	LM
Drawn	LM
Scale	AS SHOWN
Date	12/20/18

EXAMPLE: OM-3 LEFT AND RIGHT  
SIZE: 12" X 36", BLACK AND YELLOW  
STRIPED WIDTH: THE STRIPE WIDTHS SUPPLIED  
SHOULD CONFORM TO THOSE  
SPECIFIED ABOVE.

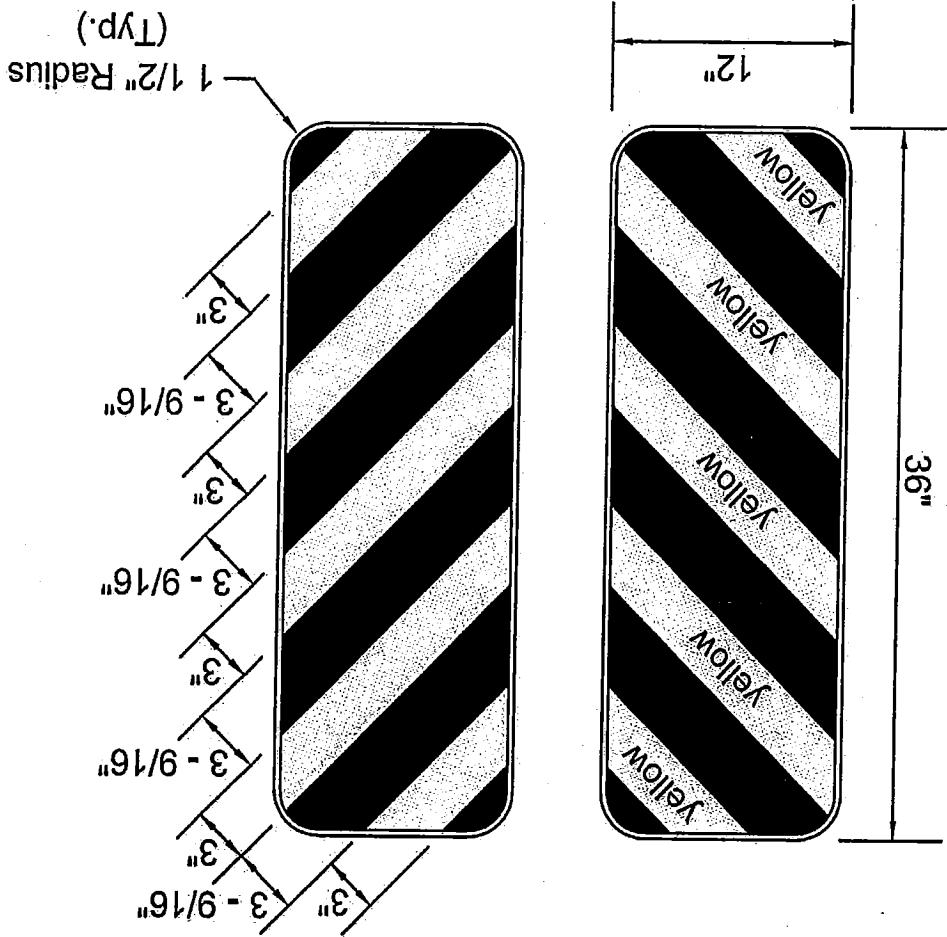

3" YELLOW STRIPE (TYPICAL)  
3 - 9/16" BLACK STRIPE (TYPICAL)

*L. Bis Tek*

**DOUGLAS COUNTY, KANSAS**

\*\*\*\*\*

FY 2014

**SPECIFICATIONS AND CONTRACT DOCUMENTS**

FOR

**SIGNS AND ACCESSORIES**

**BID NO. 14-F-0002**

\*\*\*\*\*

**DOUGLAS COUNTY, KANSAS**

**SPECIFICATIONS AND CONTRACT DOCUMENTS**

**FOR**

**PUBLIC WORKS DEPARTMENT**

**SIGNS AND ACCESSORIES**

**BID NO. 14-F-0002**

**BY**

**THE DOUGLAS COUNTY COMMISSIONERS**

**Mike Gaughan**  
**Member**

**Jim Flory**  
**Member**

**Nancy Thellman**  
**Chairman**

**Jamie Shew**  
**County Clerk**

**Keith A. Browning, P.E.**  
**Director of Public Works**

DOUGLAS COUNTY DEPARTMENT OF PUBLIC WORKS

BID NO. 14-F-0002

**NOTICE TO BIDDERS**

Notice is hereby given that sealed bids for the purchase of SIGNS AND ACCESSORIES, by the Douglas County Public Works Department, will be received in the office of the Douglas County Clerk, 1100 Massachusetts, Courthouse, Lawrence, Kansas, 66044 until 3:15 P.M., Tuesday, April 1, 2014, then publicly opened in the office of the Douglas County Clerk.

Bids must be submitted on forms provided by either the Douglas County Public Works Department, 1242 Massachusetts Street, Lawrence, Kansas or on the Internet at [www.demandstar.com](http://www.demandstar.com). The bids shall be submitted in sealed envelopes, addressed to the Office of the County Clerk, Courthouse, 1100 Massachusetts Street, Lawrence, Kansas 66044, upon which is clearly written or printed "Signs and Accessories", along with the name and address of the bidder. Any bid received by the Office of the County Clerk after the closing date and time will be returned unopened. Faxed bids will not be accepted. Douglas County is not responsible for the lost or misdirected bids, whether lost or misdirected by the postal or courier service of the bidder or the Douglas County mail room.

The awarded bidder shall agree to offer the prices and the terms and conditions herein to other government agencies who wish to participate in a cooperative purchase program with Douglas County. Other agencies will be responsible for entering into separate agreements with the awarded bidder and for all payments thereunder.

The Douglas County Department of Public Works reserves the right to reject any or all bids, or portions of bids, waive technicalities, and to purchase the items, which in the opinion of the Board, are best suited for the use intended.

Dated: March 10, 2014

DEPARTMENT OF PUBLIC WORKS  
DOUGLAS COUNTY, KANSAS  
Keith A. Browning, P.E.  
Director of Public Works

Published: Thursday, March 13, 2014  
Sunday, March 16, 2014

cc: Lawrence Journal World  
Board of County Commissioners  
County Clerk  
County Administrator  
County Shop  
Public Works Accounting  
Purchasing Department  
File

DOUGLAS COUNTY PUBLIC WORKS DEPARTMENT

Bid No. 14-F-0002  
Signs and Accessories  
FY 2014

**Instructions to Bidders**

1. It is the intent of Douglas County to purchase the various Signs and Accessories listed in this brochure.
2. Proposals must be submitted on forms provided by either the Douglas County Public Works Department, 1242 Massachusetts Street, Lawrence, Kansas or Demand Star @ www.demandstar.com. Specifications and bid requirements are included in these documents. The proposal must be left intact and will be the only form accepted as a bid by the Board of County Commissioners.
3. Bidders shall show unit prices for each item listed, shall extend all unit prices and total all extensions. All prices shall be F.O.B. Lawrence, Kansas. The County is not subject to City or State Sales Tax.
4. The Devices specified shall conform to the Manual on Uniform Traffic Control Devices, latest edition, as approved by the Federal Highway Administrator as part of the National Standard for all Highways, unless otherwise indicated in the specifications.
5. Bidders shall specify delivery date. Delivery date will be considered, as well as total price, in the selection of the successful bidder. Liquidated damages in the amount of 1% per day of the total bid price of items not received by the specified delivery date will be charged.
6. **The supplier must notify Douglas County 48 hours prior to delivery.** Douglas County reserves the right to refuse any shipment if proper advance notice is not received.
7. The back face of all finished signs shall be permanently marked with the producers name and year of manufacture. The size of the identification shall be no larger than 4" X 2", unless previously approved by the County Engineer.
8. The awarded bidder shall agree to offer the prices and the terms and conditions offered herein to other governmental agencies who wish to participate in a cooperative purchase program with Douglas County. All other agencies contracting with any vendor shall be responsible for entering into separate agreements and for all payments thereunder.
9. Bids must be sealed and received in the Douglas County Clerk's Office, Douglas County Courthouse, 1100 Massachusetts, Lawrence, Kansas 66044, prior to 3:15 P.M., Tuesday, April 1, 2014. Faxed bids will not be accepted. The County is not responsible for lost or misdirected bids, whether lost or misdirected by the postal or courier service of the bidder or the County mail room. Any bids received after the time specified will be returned unopened.
10. The County reserves the right to reject any or all bids or waive technicalities and to purchase the items which, in the opinion of the Board of County Commissioners, are best suited to the work for which they are intended. **The award will be made to the lowest and best bidder for each group of items specified (finished signs, fluorescent signs, cut out lettering, steel posts and telespar posts). Miscellaneous items will be awarded on an item by item basis.**

### Instructions to Bidders (continued)

11. All sheeting used on sign faces shall be TYPE IV High Intensity Prismatic Grade or TYPE VIII or better for Fluorescent Orange, Yellow and Yellow/Green sheeting meeting the requirements stated in Section 2201, "Retroreflective Sheeting", of the KDOT Standard Specifications, 2007 Edition, unless otherwise indicated in the bid documents. A copy of this specification is attached to this proposal, or may be viewed at <http://www.ksdot.org/burconsmain/specprov/2007/2201.pdf>. A list of pre-qualified materials can be found at <http://www.ksdot.org/burmatres/pql/default.asp>.
12. The chip and seal markers shall meet the requirements stated in Special Provision 07-22004 (Temporary Raised Pavement Markers) in Section 2200, "Reflective Materials and Accessory Items", of the KDOT Standard Specifications, 2007 Edition. A copy of this Special Provision is attached to this proposal, or may be viewed at <http://www.ksdot.org/burconsmain/specprov/2007/pdf/07-22004.pdf>.
13. All sign blanks shall be a minimum of .080 gauge aluminum (except those greater than 36" in any dimension, which shall be .10 gauge), unless otherwise specified.

STANDARD TERMS AND CONDITIONS  
DOUGLAS COUNTY, KANSAS

1. SCOPE: The following terms and conditions shall prevail unless otherwise modified by Douglas County within this bid document. Douglas County reserves the right to accept or reject any or all bids received, waive technicalities, and to purchase the products, which in the opinion of the Board of County Commissioners, is best suited to the work for which it is intended.
  
2. DEFINITIONS AS USED HEREIN:
  - a. The term "bid request" means a solicitation of a formal sealed bid.
  - b. The term "bid" means the price offered by the bidder.
  - c. The term "bidder" means the offer or vendor.
  - d. The term "County" means Douglas County, Kansas.
  - e. The term "Board of County Commissioners or "BOCC" means the governing body of Douglas County, Kansas.
  - f. The term "awarded bidder" means any bidder awarded a contract pursuant to its bid.
  
3. COMPLETING BID: Bids must be submitted only on the forms (or reproductions thereof) provided in this document. All information must be legible. Any and all corrections and/or erasures must be initialed. Each bid sheet must be signed by the authorized bidder and all required information must be provided.
  
4. CONFIDENTIALITY OF BID INFORMATION: Each bid must be sealed and submitted in an envelope clearly marked "SIGNS AND ACCESSORIES" to provide confidentiality of the bid information prior to the bid opening. Supporting documents and/or descriptive literature may be submitted with the bid. Do not indicate bid prices on literature.

All bids and supporting bid documents become public information after the bid opening and are available for public inspection by the general public in accordance with the Kansas Open Records Act.
  
5. ACCURACY OF BID: Each bid is publicly opened in the presence of the Douglas County Clerk. It is required that any and all information presented is accurate and/or will be that by which the bidder will perform if awarded the contract. If there is a discrepancy between the unit price and extended total, the unit price will prevail.
  
6. SUBMISSION OF BID: Bids must be sealed and received in the Douglas County Clerk's Office, Douglas County Courthouse, 1100 Massachusetts, Lawrence, Kansas 66044, prior to 3:15 P.M., Tuesday, April 1, 2014. Faxed bids will not be accepted. The County is not responsible for lost or misdirected bids, whether lost or misdirected by the postal or courier service of the bidder or the County mail room.
  
7. ADDENDA: All changes in connection with this bid will be issued in the form of a written addendum. Signed acknowledgment of receipt of each addendum must be submitted with the bid.



STANDARD TERMS AND CONDITIONS (continued)

8. LATE BIDS, CHANGES OR WITHDRAWALS: Bids received after the deadline designated in this bid document shall not be considered and shall be returned unopened.

Bids may be changed or withdrawn prior to the bid opening. All such transactions must be submitted in writing and received by the County Clerk's Office prior to the bid deadline. Changes or withdrawals may be made after the bid deadline only with the approval of the Board of County Commissioners. After bid opening, no changes in bid prices or other provisions of bids prejudicial to the interest of the County or fair competition shall be permitted.

9. BIDS BINDING: All bids submitted shall be binding upon the bidder if accepted by the County within fifteen (15) calendar days after the bid opening.

10. EQUIVALENT BIDS: When brand or trade names are used in the bid invitation, it is for the purpose of item identification and to establish standards for quality, style and features. Bids on equivalent items of substantially the same quality, style and features are invited unless items are marked "No Substitute." Equivalent bids must be accompanied by descriptive literature and/or specifications to receive consideration. Demonstrations and/or samples may be required and shall be supplied at no charge to the County.

11. NEW MATERIALS, SUPPLIES OR EQUIPMENT: Unless otherwise specified, all materials, supplies or equipment offered by a bidder shall be new, unused, of recent manufacture, first class in every respect and suitable for their intended purpose. All equipment shall be assembled, and ready for operation when delivered.

12. WARRANTY: Supplies or services furnished as a result of this bid shall be covered by the most favorable commercial warranties, expressed or implied, that the bidder and/or manufacturer gives to any customer. The rights and remedies provided herein are in addition to and do not limit any rights afforded to the County by any other clause of this bid. The County reserves the right to request from bidders a separate manufacturer certification of all statements made in the proposal.

13. METHOD OF AWARD AND NOTIFICATION: Bids will be evaluated and the award made to the lowest and best, responsive and responsible bidder(s) whose bid conforms to the specifications and whose bid is considered to be the best value in the opinion of the Board of County Commissioners.

The County reserves the right to accept or reject any or all bids and any part of a bid and to waive informalities, technical defects, and minor irregularities in bids received. **The award will be made to the lowest and best bidder for each group of items specified (finished signs, fluorescent signs, cut out lettering, steel posts and telespar posts). Miscellaneous items will be awarded on an item by item basis.**

The signed bid shall be considered an offer on the part of the bidder; such offer shall be deemed accepted upon issuance by the County of a Purchase Order or other contractual document.

STANDARD TERMS AND CONDITIONS (continued)

14. DELIVERY TERMS: All deliveries shall be F.O.B. Lawrence, Kansas and all freight charges shall be included in the bid price. Delivery date shall be considered as a cost factor in the determination of award.
15. DAMAGED AND/OR LATE SHIPMENTS: The County has no obligation to accept damaged shipments and reserves the right to return at the vendor's expense damaged merchandise even though the damage was not apparent or discovered until after receipt of the items. The Vendor is responsible to notify the Douglas County Department of Public Works of any late or delayed shipments. The County reserves the right to cancel all or any part of an order if the shipment is not made as promised.
16. CREDIT TERMS: Bidder shall indicate all discounts for full and/or prompt payment. Discounts offered shall be computed from date of receipt of correct invoice or receipt and acceptance of products, whichever is later.
17. SELLERS INVOICE: Invoices shall be prepared and submitted in at least two copies to the address shown on the Purchase Order or bid document. Separate invoices are required for each Purchase Order or bid document. Invoices shall contain the following information: Purchase order number and date, bid number, item number, description of supplies or services, sizes, unit of measure, quantity, unit price and extended totals.
18. TAX EXEMPT: The County and its agencies are exempt from State and local sales taxes by K.S.A. 79-3606, as amended. Situs of all transactions under the order(s) that shall be derived from this request shall be deemed to have been accomplished within the State of Kansas.
19. SAFETY: All practices, materials, supplies and equipment shall comply with the Federal Occupational Safety and Health Act, as well as any pertinent Federal, state and/or local safety or environmental codes.
20. DISCLAIMER OF LIABILITY: The County, or any of its agencies, will not hold harmless or indemnify any bidder for any liability whatsoever.
21. HOLD HARMLESS: The awarded bidder agrees to protect, defend, indemnify and hold the Board of County Commissioners, its officers, employees and agents free and harmless from and against any and all losses, penalties, damages, settlements, costs, charges, professional fees or other expenses or liabilities of every kind and character arising out of or relating to any and all claims, liens, demands, obligations, actions, proceedings or causes of action of every kind and character in connection with or arising directly or indirectly out of this agreement and/or the performance hereof. Without limiting the generality of the foregoing, and all such claims, etc., relating to personal injury, infringement of any patent, trademark, copyright (or application for any thereof) or of any other tangible or intangible personal or property right, or actual or alleged violation of any applicable statute, ordinance, administrative order, rule or regulation, or decree of any court, shall be included in the indemnity hereunder. The awarded bidder further agrees to investigate, handle, respond to, provide defense for and defend any such claims, etc., at his/her sole expense and agrees to bear all other costs and expenses related thereto, even if such claim is groundless, false or fraudulent.

STANDARD TERMS AND CONDITIONS (continued)

22. LAW GOVERNING: All contractual agreements shall be subject to, governed by, and construed according to the laws of the State of Kansas.
23. ANTI-DISCRIMINATION CLAUSE: No bidder on this request shall in any way, directly or indirectly, discriminate against any person because of age, race, color, handicap, sex, national origin, or religious creed.

BID  
For  
VARIOUS SIGNS AND ACCESSORIES

**Bid No. 14-F-0002**

Price shall include delivery to the Douglas County Shop, 23rd and Santa Fe Tracks, 711 E 23<sup>rd</sup> St., Lawrence, Kansas.

The Devices specified shall conform to the Manual on Uniform Traffic Control Devices, latest edition, as approved by the Federal Highway Administrator as part of the National Standard for all Highways unless otherwise indicated in the Specifications and Contract Documents.

The Douglas County Public Works 2014 Combined Sign Bid attached hereto is incorporated herein by this reference and is the undersigned bidders bid.

Bids must be returned to the Office of the Douglas County Clerk no later than, 3:15 P.M., Tuesday, April 1, 2014.

**The bidder shall notify Douglas County 48 hours prior to delivery.**

Date available for delivery: Entire order 5 weeks or less  
after approval

Bidder: Ibis Tek  
724-431-2085

By: Rachel Berglund

Recommended for Approval:

DOUGLAS COUNTY, KANSAS  
Board of County Commissioners

Keith A. Browning  
Keith A. Browning, P.E.  
Director of Public Works

\_\_\_\_\_  
Nancy Thellman, Chairman

\_\_\_\_\_  
Mike Gaughan, Member

\_\_\_\_\_  
Jim Flory, Member

\_\_\_\_\_  
Date

SECTION 2201

RETROREFLECTIVE SHEETING

2201.1 DESCRIPTION

This specification covers Type I and all Types of High Intensity retroreflective sheeting. This includes both non-exposed glass bead lens and microprismatic sheeting.

2201.2 REQUIREMENTS

a. **General.** Provide retroreflective sheeting that complies with ASTM D 4956 (latest revision) except for the color limits as specified in subsection 2201.2b. The type to be provided will be shown in the Contract Documents. Types and classes are as defined in ASTM D 4956.

b. **Color.** The colors of the retroreflective sheeting are white, yellow, red, orange, green, blue, brown, fluorescent orange, fluorescent yellow, and fluorescent yellow-green. Provide colors that comply with the chromaticity limits as shown in TABLE 2201-1 for both Type I and Type III sheeting and TABLE 2201-2 for all other Types of High Intensity sheeting (Type IV through Type XI). Provide fluorescent colors that comply with the chromaticity limits in ASTM D 4956 (latest revision).

TABLE 2201-1: COLOR SPECIFICATION (Type I and Type III)								
COLOR	Chromaticity Coordinates							
	1		2		3		4	
	x	y	x	y	x	y	x	y
White	0.310	0.313	0.338	0.342	0.325	0.355	0.300	0.327
Yellow	0.496	0.503	0.545	0.454	0.505	0.433	0.460	0.474
Red	0.574	0.337	0.665	0.345	0.708	0.292	0.613	0.297
Orange	0.558	0.352	0.636	0.364	0.570	0.429	0.506	0.404
Green	0.130	0.387	0.180	0.410	0.140	0.521	0.098	0.490
Blue	0.138	0.065	0.112	0.135	0.160	0.170	0.176	0.120
Brown	0.430	0.340	0.610	0.390	0.550	0.450	0.430	0.390

TABLE 2201-2: COLOR SPECIFICATION (Type IV – Type XI)								
COLOR	Chromaticity Coordinates							
	1		2		3		4	
	x	y	x	y	x	y	x	y
White	0.310	0.313	0.328	0.331	0.316	0.345	0.300	0.327
Yellow	0.515	0.484	0.545	0.454	0.505	0.433	0.475	0.460
Red	0.586	0.324	0.664	0.336	0.708	0.292	0.613	0.297
Orange	0.558	0.352	0.636	0.364	0.570	0.429	0.506	0.404
Green	0.130	0.387	0.180	0.410	0.155	0.478	0.107	0.457
Blue	0.138	0.065	0.112	0.135	0.160	0.170	0.176	0.120
Brown	0.430	0.340	0.610	0.390	0.550	0.450	0.430	0.390

c. **Conformable Retroreflective Sheeting.** Provide High Intensity retroreflective sheeting that has a conformable aluminum foil backing with an aggressive pressure sensitive adhesive. This material is designed for application to moderately rough or porous metal, wood or masonry surfaces. Provide material that complies with ASTM D 4956 (latest revision) with the following exceptions and additions:

- (1) Conformable aluminum backing thickness – 0.005 inches to 0.010 inches.
- (2) Follow all manufacturers' recommendations for application procedures and temperatures.

2201.3 MANUFACTURER WARRANTY

The following warranty conditions apply only to the retroreflective sheeting manufacturer. Provide a product warranty for a minimum period of 10 years on all Types of High Intensity retroreflective sheeting, for placement on permanent signing. Failure to comply with this warranty may be cause for removal from the prequalified list.

The High Intensity retroreflective sheeting warranty must comply with the following requirements and obligations:

- Certification: Submit with each lot or shipment, a certification which states that the material supplied is subject to and complies with the requirements. Include in the certification, the manufacturer's office, address, phone number and the contact for potential claims under the provisions of this warranty. Provide documentation as to which signs were fabricated from each lot.
- Field Performance: Field Performance applies to retroreflective sheeting applied to sign blank materials or overlaid on existing signs. The field performance obligation period begins with the date of erection. The sheeting is considered unsatisfactory if it has deteriorated due to natural causes to the extent that the sign is ineffective for its intended purpose when viewed from a moving vehicle under normal day and night driving conditions or shows any of the following defects:
  - Cracking discernible with the unaided eye from a driver's position at a distance of 50 feet or greater from the sign;
  - More than 25% loss of specular gloss and cracking, scaling, pitting, orange peel, delamination, edge lifting or curling;
  - Peeling in excess of 3/8 inch;
  - Shrinkage in excess of 3/16 inch total per yard of sheeting width;
  - Fading or loss of color to the extent that retroreflective sheeting color fails to comply with the subsection 2201.2b., or;
  - Loss of retroreflectivity reducing the coefficient of retroreflection as measured by a retroreflectometer to less than the minimum specified in TABLE 2201-3 at 0.2° observation and -4° entrance angles. Make all measurements after cleaning the sign.

TABLE 2201-3: MINIMUM COEFFICIENT OF RETROREFLECTION CANDELAS PER SQUARE METER PER LUX	
Sheeting Color	Min. Coefficient
White	200
Yellow	136
Green	36
Red	36
Blue	16
Brown	9

**Defective Material Replacement:** When traffic signs with High Intensity sheeting fail to comply with the field performance requirements, re-sheet or replace the signs at no cost to the Douglas County for materials and labor. Employ a contractor qualified by the KDOT to perform signing work. Install highway signs, as shown in the Contract Documents and the M.U.T.C.D. (latest edition) and provide proper traffic control.

Replace all defective material within 60 days after written notification by Douglas County. Signs not corrected within 60 days, will be removed and replaced by Douglas County. Signs removed by Douglas County will be placed in storage for inspections by the manufacturer, and the manufacturer will be billed for all costs of replacement of the sheeting.

When more than 25% of the signs within a lot fail to comply with the requirements, replace all signs made from that lot.

#### 2201.4 PREQUALIFICATION

Manufacturers desiring to provide material under this specification are to submit prequalification samples of each type, class and color covered by this specification which they wish to prequalify. Each sample consists of 3 pieces 24 inches square.

Forward the prequalification samples to the Engineer of Tests, Materials and Research Center, 2300 Van Buren, Topeka, KS 66611. Samples will be tested for compliance with all requirements of this specification. Each Manufacturer will be notified of the test results.

If the prequalification samples of retroreflective sheeting comply with this specification, the product will be placed on a list of prequalified products maintained by the Bureau of Materials and Research. No retroreflective sheeting will be used on KDOT projects unless it has been prequalified. Manufacturers will be required to requalify at intervals determined by the Engineer of Tests.

Testing and evaluation by KDOT may be waived if complete testing has been performed on the identical product by AASHTO National Transportation Product Evaluation Program (NTPEP). Forward an official copy of the test report along with evidence that the product referenced is identical to that submitted for prequalification, to the Engineer of Tests for evaluation.

## **2201.5 METHODS OF TESTS**

All tests will be conducted in accordance with ASTM D 4956 with the exception of artificial weathering. Artificial weathering will be conducted according to ASTM G 155, Cycle 1, with the following additions and exceptions:

- At the end of each 20 hour cycle, the panels will be placed in a cold cabinet at approximately 0°F for one hour. After removal from the cold cabinet, panels will be returned to the weatherometer to await the start of the next cycle.
- Water used in the weatherometer will be city water softened to a total hardness content of less than 5 parts per million expressed as calcium carbonate.

## **2201.6 BASIS OF ACCEPTANCE**

### **a. Permanent Sheeting.**

- (1) Prequalification as required by subsection 2201.4.
- (2) Satisfactory results of tests conducted at MRC. Each lot of sheeting will be sampled at destination by a representative of the KDOT and will be subjected to a visual examination and tested for physical properties as necessary to verify that the sheeting complies with this specification.
- (3) Receipt of the warranty certification as specified in subsection 2201.3 by the County Engineer.

**b. Temporary Sheeting.** Retroreflective sheeting used to manufacture temporary traffic control signs will be accepted on the basis of a certification prepared by the contractor stating that the retroreflective sheeting used to manufacture the signs was prequalified under this specification, and visual inspection by the Engineer for condition and other requirements.

**KANSAS DEPARTMENT OF TRANSPORTATION  
SPECIAL PROVISION TO THE  
STANDARD SPECIFICATIONS, EDITION 2007**

Add a new SECTION in DIVISION 2200:

**TEMPORARY RAISED PAVEMENT MARKERS**

**1.0 DESCRIPTION**

This specification covers temporary raised pavement markers for lane marking and delineation. This includes both Flexible and Rigid (Types I and II) markers for use on both Portland cement concrete and asphalt surfaces.

**2.0 REQUIREMENTS**

**a. General.**

(1) Provide temporary reflective markers as shown in the Contract Documents. The markers shall be readily visible at night, from a minimum of 300 feet, when viewed with high beam automobile headlamps. Prior to use, markers must be approved by the Engineer. The marker shall be the same color as the reflective elements. All markers shall be capable of sustaining 2000 direct wheel-over impacts at 60 mph without losing adhesion to the roadway or sustaining damage to the marker body.

(2) Provide Flexible temporary raised pavement markers which consist of an L-shaped flexible polyurethane body with prismatic reflective sheeting on both faces. The reflective sheeting shall be a minimum of 1 square inch spread over the 4" wide marker. The markers shall have minimum dimensions of 4 inches wide x 2 inches high with a 1 inch wide base leg. Thickness of the body shall be a minimum of 0.06 inches. The marker shall have an affixed pressure sensitive adhesive, protected by a release paper, for application to the pavement surface. Attach a clear flexible plastic cover to the vertical section of the marker to protect the reflective material during surfacing operations. The cover shall withstand the work and be easily removed after the operation. The markers shall not cause any damage to the automobile.

(3) Provide Rigid (Type I) temporary raised pavement markers constructed of traffic bearing high impact plastic with prismatic reflective faces. The base of the markers shall have minimum dimensions of 2.5 inches wide, 4 inches long and 0.4 inches high. The base of the marker shall be flat. Markers shall be reflectorized with one or more reflective faces on each side using either an acrylic retroreflector, or retroreflective sheeting. Each face shall contain a minimum of 0.38 square inches of reflective surface. The adhesive used shall not stain the pavement and will allow the markers to be easily removed without damage to the roadway surface. If the marker is self adhesive, it shall be pre-coated with an affixed pressure sensitive adhesive, protected by a release paper.

(4) Provide Rigid (Type II) or brick markers constructed of traffic bearing high impact plastic with prismatic reflective faces. The marker shall have minimum dimensions of 2.5 inches high, 7.5 inches wide and 13 inches long. The base of the marker shall be flat. Markers shall be reflectorized with two or more reflective faces on each side using either an acrylic retroreflector, or retroreflective sheeting. Each face shall contain a minimum of 3.75 square inches of reflective surface. The adhesive used will allow the markers to be removed without damage to the roadway surface. If the marker is self adhesive, it shall be pre-coated with an affixed pressure sensitive adhesive, protected by a release paper.

**b. Retroreflectivity.** Provide markers in white or yellow which comply with the minimum requirements shown in TABLE 1:

<b>TABLE 1: RETROREFLECTIVITY REQUIREMENTS</b>	
<b>Color</b>	<b>Millicandelas/sq m/lux (min.)<sup>a</sup> (measured at 0.2° observation angle and 0° entrance angle)</b>
White	3.0
Yellow	1.8

<sup>a</sup> Flexible markers must meet these requirements before and after durability testing



c. **Color.** Markers shall be white or yellow in color, solid throughout, and match the color of the lane line on which the marker will be placed under both daylight and nighttime conditions.

d. **Durability.** Flexible markers, as defined in subsection 2.0a.(2), must withstand 2000 revolutions on a small-wheel circular track. 12 markers of each color will be tested. No more than 3 markers shall move from their original position during testing.

### 3.0 TEST METHODS

a. **Retroreflectivity.** Test in accordance with ASTM E 809.

b. **Durability.** Test in accordance with ASTM E 660, with the following variations:

(1) Mount two opposite wheels with 11 x 6.00 x 5 nylon smooth non-pattern tread tires with a total load of 50 pounds on each tire. Maintain tire pressure at 25 psi. Mount the wheels perpendicular to the specimens and toe out 2° to produce a slight abrading action.

(2) Apply markers, according to the manufacturer's recommendations, to 6 inch diameter dense grade asphalt concrete cores, which have been compacted at 3000 psi for 2 minutes.

### 4.0 PREQUALIFICATION

Manufacturers wishing to supply markers to KDOT projects must have their product tested by the AASHTO National Transportation Product Evaluation Program (NTPEP). Submit 12 flexible markers or 2 rigid markers of each color for which prequalification is requested, and an official copy of the NTPEP test report to the Engineer of Tests, Materials and Research Center, 2300 Van Buren, Topeka, KS 66611. Include evidence that the product offered is identical to that described in the test report, and information regarding the recommended adhesive, if any is required. Prequalification will be based on satisfactory compliance of NTPEP results and laboratory testing with subsection 2.0.

### 5.0 BASIS OF ACCEPTANCE

Prequalification as required by subsection 4.0.

Receipt and approval of a Type C certification as specified in DIVISION 2600.

Visual inspection for condition and dimensional requirements.

09-06-12 M&R (SML/KJS)  
Jan-13 Letting

DOUGLAS COUNTY PUBLIC WORKS  
2014 COMBINED SIGN BID

3/5/2014

*Handwritten initials/signature*

FINISHED SIGNS

MUTCD #	SIZE	DESCRIPTION	COLOR	SHEETING	REMARKS	# TO ORDER	UNIT COST	EXTENDED COST
M1-6	24 X 24	DOUGLAS COUNTY	YELLOW/BLUE	TY IV, H/I PRISM.	NO ROUTE NUMBER	10	\$ 24.19	\$ 241.90
M1-6	24 X 24	DOUGLAS COUNTY 1	YELLOW/BLUE	TY IV, H/I PRISM.	ROUTE MARKER	4	\$ 24.19	\$ 96.76
M1-6	24 X 24	DOUGLAS COUNTY 1S	YELLOW/BLUE	TY IV, H/I PRISM.	ROUTE MARKER	5	\$ 24.19	\$ 120.95
M1-6	24 X 24	DOUGLAS COUNTY 1W	YELLOW/BLUE	TY IV, H/I PRISM.	ROUTE MARKER	5	\$ 24.19	\$ 120.95
M1-6	24 X 24	DOUGLAS COUNTY 1E	YELLOW/BLUE	TY IV, H/I PRISM.	ROUTE MARKER	5	\$ 24.19	\$ 120.95
M1-6	24 X 24	DOUGLAS COUNTY 2	YELLOW/BLUE	TY IV, H/I PRISM.	ROUTE MARKER	5	\$ 24.19	\$ 120.95
M1-6	24 X 24	DOUGLAS COUNTY 3	YELLOW/BLUE	TY IV, H/I PRISM.	ROUTE MARKER	5	\$ 24.19	\$ 120.95
M1-6	24 X 24	DOUGLAS COUNTY 4	YELLOW/BLUE	TY IV, H/I PRISM.	ROUTE MARKER	4	\$ 24.19	\$ 96.76
M1-6	24 X 24	DOUGLAS COUNTY 6	YELLOW/BLUE	TY IV, H/I PRISM.	ROUTE MARKER	10	\$ 24.19	\$ 241.90
M1-6	24 X 24	DOUGLAS COUNTY 438	YELLOW/BLUE	TY IV, H/I PRISM.	ROUTE MARKER	7	\$ 24.19	\$ 169.33
M1-6	24 X 24	DOUGLAS COUNTY 442	YELLOW/BLUE	TY IV, H/I PRISM.	ROUTE MARKER	5	\$ 24.19	\$ 120.95
M1-6	24 X 24	DOUGLAS COUNTY 460	YELLOW/BLUE	TY IV, H/I PRISM.	ROUTE MARKER	10	\$ 24.19	\$ 241.90
M1-6	24 X 24	DOUGLAS COUNTY 1023	YELLOW/BLUE	TY IV, H/I PRISM.	ROUTE MARKER	10	\$ 24.19	\$ 241.90
M1-6	24 X 24	DOUGLAS COUNTY 1029	YELLOW/BLUE	TY IV, H/I PRISM.	ROUTE MARKER	10	\$ 241.19	\$ 241.90
M1-6	24 X 24	DOUGLAS COUNTY 1039	YELLOW/BLUE	TY IV, H/I PRISM.	ROUTE MARKER	7	\$ 24.19	\$ 169.33
M4-6	24 X 12	"END" - AUXILIARY SIGN	BLACK/WHITE	TY IV, H/I PRISM.		5	\$ 22.71	\$ 113.55
M6-1	21 X 15	DIRECTIONAL SIGN	BLACK/WHITE	TY IV, H/I PRISM.		10	\$ 23.96	\$ 239.60
OM2-2V	6 X 12	TYPE 2 OBJECT MARKER	YELLOW	TY IV, H/I PRISM.		400	\$ 9.31	\$ 3724.00
OM2-2V	6 X 12	TYPE 2 OBJECT MARKER	WHITE	TY IV, H/I PRISM.		50	\$ 9.31	\$ 465.50
OM3-L	12 X 36	OBJECT MARKER TYPE III - LEFT	BLACK/YELLOW	TY IV, H/I PRISM.	SEE PLAN DETAILS	254	\$ 32.03	\$ 8135.62
OM3-R	12 X 36	OBJECT MARKER TYPE III - RIGHT	BLACK/YELLOW	TY IV, H/I PRISM.	SEE PLAN DETAILS	250	\$ 32.03	\$ 8007.50
OM4-3	18 X 18	END OF ROAD MARKER	RED	TY IV, H/I PRISM.		24	\$ 23.30	\$ 559.20
R1-1	30 X 30	STOP SIGN	WHITE/RED	TY IV, H/I PRISM.		20	\$ 56.61	\$ 1132.20
R1-2	30 X 30 X 30	YIELD	WHITE/RED	TY IV, H/I PRISM.		1	\$ 56.61	\$ 56.61
R1-3P	18 X 6	ALL WAY	WHITE/RED	TY IV, H/I PRISM.		8	\$ 11.70	\$ 93.60
R2-1	24 X 30	"SPEED LIMIT"	BLACK/WHITE	TY IV, H/I PRISM.	NO SPEED LIMIT NUMBER	7	\$ 46.39	\$ 324.73
R2-1-25	24 X 30	"SPEED LIMIT 25"	BLACK/WHITE	TY IV, H/I PRISM.		4	\$ 46.39	\$ 185.56
R2-1-40	24 X 30	"SPEED LIMIT 40"	BLACK/WHITE	TY IV, H/I PRISM.		5	\$ 46.39	\$ 231.95
R2-1-55	24 X 30	"SPEED LIMIT 55"	BLACK/WHITE	TY IV, H/I PRISM.		20	\$ 46.39	\$ 927.80
R5-1	30 X 30	"DO NOT ENTER"	WHITE/RED	TY IV, H/I PRISM.		2	\$ 56.61	\$ 113.22
R7-1	12 X 18	NO PARKING <—>	WHITE/RED	TY IV, H/I PRISM.	DOUBLE ARROW BELOW "NO PARKING"	5	\$ 17.20	\$ 86.00
R7-1	18 X 24	NO PARKING <—>	WHITE/RED	TY IV, H/I PRISM.	DOUBLE ARROW BELOW "NO PARKING"	4	\$ 29.75	\$ 119.00
R7-1L	12 X 18	NO PARKING <—	WHITE/RED	TY IV, H/I PRISM.	LEFT ARROW BELOW "NO PARKING"	4	\$ 17.20	\$ 68.80
R7-1L	18 X 24	NO PARKING <—	WHITE/RED	TY IV, H/I PRISM.	LEFT ARROW BELOW "NO PARKING"	7	\$ 29.75	\$ 208.25
R7-1R	12 X 18	NO PARKING —>	WHITE/RED	TY IV, H/I PRISM.	RIGHT ARROW BELOW "NO PARKING"	5	\$ 17.20	\$ 86.00
R7-1R	18 X 24	NO PARKING —>	WHITE/RED	TY IV, H/I PRISM.	RIGHT ARROW BELOW "NO PARKING"	2	\$ 29.75	\$ 59.50
R11-2	48 X 30	"ROAD CLOSED"	BLACK/WHITE	TY IV, H/I PRISM.	2 LINES	7	\$ 88.12	\$ 616.84
R11-3a	60 X 30	"ROAD CLOSED _ MILES AHEAD LOCAL TRAFFIC ONLY"	BLACK/WHITE	TY IV, H/I PRISM.	3 LINES	4	\$ 109.13	\$ 436.52
R12-1	24 X 30	"WEIGHT LIMIT _ TONS"	BLACK/WHITE	TY IV, H/I PRISM.		5	\$ 46.39	\$ 231.95
R12-5	24 X 36	"WEIGHT LIMIT _ TONS"	BLACK/WHITE	TY IV, H/I PRISM.	3 TIER W/ NO DISPLAYED # - "T" ONLY	10	\$ 54.85	\$ 548.05

\$2,411.90  
\$169.33

SUBTOTAL FINISHED SIGNS

\$ 29,239.38

~~\$ 29,238.93~~ NP

\$ 31,409.38 NP

Bid Submitted By: Diana Holliday - Ibis Tek

Authorized Signature: \_\_\_\_\_

*Handwritten signature: Rachel Bordwell*

DOUGLAS COUNTY PUBLIC WORKS  
2014 COMBINED SIGN BID

3/5/2014

FINISHED SIGNS (CONTINUED)

MUTCD #	SIZE	DESCRIPTION	COLOR	SHEETING	REMARKS	# TO ORDER	UNIT COST	EXTENDED COST
W1-1L	30 X 30	LEFT TURN ARROW	BLACK/YELLOW	TY IV, H/I PRISM.		4	\$ 56.61	\$ 226.44
W1-1L	48 X 48	LEFT TURN ARROW	BLACK/YELLOW	TY IV, H/I PRISM.		2	\$ 137.18	\$ 274.36
W1-1R	36 X 36	RIGHT TURN ARROW	BLACK/YELLOW	TY IV, H/I PRISM.		4	\$ 79.38	\$ 317.52
W1-1R	48 X 48	RIGHT TURN ARROW	BLACK/YELLOW	TY IV, H/I PRISM.		3	\$ 137.18	\$ 411.54
W1-2L	30 X 30	CURVE SIGN - LEFT	BLACK/YELLOW	TY IV, H/I PRISM.		2	\$ 56.61	\$ 113.22
W1-2L	36 X 36	CURVE SIGN - LEFT	BLACK/YELLOW	TY IV, H/I PRISM.		3	\$ 79.38	\$ 238.14
W1-2L	48 X 48	CURVE SIGN - LEFT	BLACK/YELLOW	TY IV, H/I PRISM.		2	\$ 137.18	\$ 274.36
W1-2R	30 X 30	CURVE SIGN - RIGHT	BLACK/YELLOW	TY IV, H/I PRISM.		5	\$ 56.61	\$ 283.05
W1-2R	36 X 36	CURVE SIGN - RIGHT	BLACK/YELLOW	TY IV, H/I PRISM.		4	\$ 79.38	\$ 317.52
W1-3R	30 X 30	REVERSE TURN SIGN - RIGHT	BLACK/YELLOW	TY IV, H/I PRISM.		1	\$ 56.61	\$ 56.61
W1-6	36 X 18	ONE-DIRECTION LARGE ARROW	BLACK/YELLOW	TY IV, H/I PRISM.		4	\$ 42.58	\$ 170.32
W1-6	48 X 24	ONE-DIRECTION LARGE ARROW	BLACK/YELLOW	TY IV, H/I PRISM.		3	\$ 71.77	\$ 215.31
W1-7	36 X 18	TWO-DIRECTION LARGE ARROW	BLACK/YELLOW	TY IV, H/I PRISM.		3	\$ 42.58	\$ 127.74
W1-7	48 X 24	TWO-DIRECTION LARGE ARROW	BLACK/YELLOW	TY IV, H/I PRISM.		5	\$ 71.77	\$ 358.85
W1-8	18 X 24	CHEVRON ALIGNMENT SIGN	BLACK/YELLOW	TY IV, H/I PRISM.		60	\$ 29.75	\$ 1785.00
W2-4	30 X 30	T-INTERSECTION AHEAD	BLACK/YELLOW	TY IV, H/I PRISM.		3	\$ 56.61	\$ 169.83
W3-5	36 X 36	REDUCE SPEED LIMIT AHEAD 30	BL-WHITE/YELLOW	TY IV, H/I PRISM.		4	\$ 79.38	\$ 317.52
W3-5	36 X 36	REDUCE SPEED LIMIT AHEAD 40	BL-WHITE/YELLOW	TY IV, H/I PRISM.		5	\$ 79.38	\$ 396.90
W8-6	30 X 30	TRUCK CROSSING	BLACK/YELLOW	TY IV, H/I PRISM.		4	\$ 56.61	\$ 226.44
W8-17	30 X 30	SHOULDER DROP OFF (SYMBOL)	BLACK/YELLOW	TY IV, H/I PRISM.		7	\$ 56.61	\$ 396.27
W10-1	36" DIA	GRADE CROSSING ADVANCE WARNING	BLACK/YELLOW	TY IV, H/I PRISM.	(RAILROAD EMBLEM)	6	\$ 79.38	\$ 476.28
W11-8	36 X 36	EMERGENCY VEHICLE	BLACK/YELLOW	TY IV, H/I PRISM.		5	\$ 79.38	\$ 396.90
W11-8P	24 X 18	"FIRE STATION"	BLACK/YELLOW	TY IV, H/I PRISM.	TWO LINES	4	\$ 29.75	\$ 119.00
W13-1P	18 X 18	"20 MPH"	BLACK/YELLOW	TY IV, H/I PRISM.		5	\$ 23.33	\$ 116.65
W13-1P	18 X 18	"35 MPH"	BLACK/YELLOW	TY IV, H/I PRISM.		5	\$ 23.33	\$ 116.65
W13-1P	24 X 24	"45 MPH"	BLACK/YELLOW	TY IV, H/I PRISM.		6	\$ 37.92	\$ 227.52
W14-1	30 X 30	"DEAD END"	BLACK/YELLOW	TY IV, H/I PRISM.		5	\$ 56.61	\$ 283.05
W14-2	30 X 30	"NO OUTLET"	BLACK/YELLOW	TY IV, H/I PRISM.	DIAMOND SHAPE	6	\$ 56.61	\$ 339.66
W14-3	48 X 48 X 36	"NO PASSING ZONE" PENNANT	BLACK/YELLOW	TY IV, H/I PRISM.	2 HOLES FOR 1 POST MOUNT	20	\$ ?	\$ ?
W16-2P	18 X 12	"500 FEET" PLAQUE	BLACK/YELLOW	TY IV, H/I PRISM.		12	\$ 17.020	\$ 206.40
W20-3	30 X 30	ROAD CLOSED	BLACK/YELLOW	TY IV, H/I PRISM.		6	\$ 56.61	\$ 339.66
N/A	30 X 30	"FLOOD AREA AHEAD"	BLACK/YELLOW	TY IV, H/I PRISM.	DIAMOND SHAPE	4	\$ 56.61	\$ 226.44

SUBTOTAL FINISHED SIGNS \$ 9525.15

TOTAL COST FINISHED SIGNS \$ 38,764.53

\$ 38,764.08

\* NOT COMPLIANT

Bid Submitted By: Diana Halliday  
This Tek

Authorized Signature: Rachel Berglund

DOUGLAS COUNTY PUBLIC WORKS  
2014 COMBINED SIGN BID

3/5/2014

FLUORESCENT SIGNS

MUTCD #	SIZE	DESCRIPTION	COLOR	SHEETING	REMARKS	# TO ORDER	UNIT COST	EXTENDED COST
M4-8	24 X 12	DETOUR	FLUORESCENT ORANGE	TY VIII OR BETTER		21	\$ 25.91	\$ 544.11-
M4-8a	24 X 18	END DETOUR	FLUORESCENT ORANGE	TY VIII OR BETTER		4	\$ 36.26	\$ 145.04-
M4-10L	48 X 18	DETOUR ARROW - LEFT	FLUORESCENT ORANGE	TY VIII OR BETTER		2	\$ 68.44	\$ 136.88-
M4-10R	48 X 18	DETOUR ARROW - RIGHT	FLUORESCENT ORANGE	TY VIII OR BETTER		2	\$ 68.44	\$ 136.88-
S3-1	30 X 30	SCHOOL BUS STOP AHEAD	FLUOR. YELLOW/GREEN	TY VIII OR BETTER	FLUORESCENT YEL/GREEN	4	\$ 70.17	\$ 280.68-
W1-7	60 X 30	TWO-DIRECTION LARGE ARROW	FLUORESCENT YELLOW	TY VIII OR BETTER	FLUORESCENT YELLOW	4	\$ 136.25	\$ 545.00-
W8-1	36 X 36	BUMP	FLUORESCENT ORANGE	TY VIII OR BETTER		5	\$ 98.90	\$ 494.50-
W8-4	36 X 36	SOFT SHOULDER	FLUORESCENT ORANGE	TY VIII OR BETTER		6	\$ 98.90	\$ 593.40-
W8-8	36 X 36	ROUGH ROAD	FLUORESCENT ORANGE	TY VIII OR BETTER		1	\$ 98.90	\$ 98.90-
W8-9	36 X 36	LOW SHOULDER	FLUORESCENT ORANGE	TY VIII OR BETTER		8	\$ 98.90	\$ 791.20-
W8-11	36 X 36	UNEVEN LANES	FLUORESCENT ORANGE	TY VIII OR BETTER		8	\$ 98.90	\$ 791.20-
W20-1	36 X 36	ROAD WORK AHEAD	FLUORESCENT ORANGE	TY VIII OR BETTER		21	\$ 98.90	\$ 2076.90-
W20-1	48 X 48	ROAD WORK AHEAD	FLUORESCENT ORANGE	TY VIII OR BETTER		4	\$ 171.81	\$ 687.56- \$687.24
W20-2	48 X 48	DETOUR AHEAD	FLUORESCENT ORANGE	TY VIII OR BETTER		6	\$ 171.89	\$ 1031.34-
W20-2	48 X 48	DETOUR 500 FT	FLUORESCENT ORANGE	TY VIII OR BETTER		4	\$ 171.89	\$ 687.56-
W20-3	48 X 48	"ROAD CLOSED"	FLUORESCENT ORANGE	TY VIII OR BETTER	2 LINES	4	\$ 171.89	\$ 687.56-
W20-3	48 X 48	ROAD CLOSED 500 FT	FLUORESCENT ORANGE	TY VIII OR BETTER		5	\$ 171.89	\$ 859.45-
W20-4	36 X 36	"ONE LANE ROAD AHEAD"	FLUORESCENT ORANGE	TY VIII OR BETTER	3 LINES	14	\$ 98.90	\$ 1384.60-
W21-5	36 X 36	SHOULDER WORK	FLUORESCENT ORANGE	TY VIII OR BETTER		8	\$ 99.90	\$ 799.20- \$719.20
N/A	48 X 48	"TRUCKS TURNING"	FLUORESCENT ORANGE	TY VIII OR BETTER	2 LINES	4	\$ 171.89	\$ 687.56-

TOTAL COST FLUORESCENT SIGNS \$13,451.52  
\$13,379.20<sup>MP</sup>

CUT OUT LETTERING

SERIES	SIZE	DESCRIPTION	CHARACTERS	COLOR	SHEETING	REMARKS	# TO ORDER (PKG)*	UNIT COST	EXTENDED COST
SERIES D	10"	NUMBER "1"	25	BLACK	TY IV, H/I PRISM.	PRESSURE SENSITIVE	1	\$ 16.25	\$ 16.25-
SERIES D	10"	NUMBER "4"	25	BLACK	TY IV, H/I PRISM.	PRESSURE SENSITIVE	1	\$ 16.25	\$ 16.25-
SERIES C	8"	NUMBER "4"	25	YELLOW	TY IV, H/I PRISM.	PRESSURE SENSITIVE	1	\$ 13.60	\$ 13.60-

\* NOTE: \*ASSUMING EACH PACKAGE CONTAINS 25 CHARACTERS TOTAL COST CUT OUT LETTERING \$ 46.10<sup>MP</sup>

Diana Halliday

Bid Submitted By: Tbis Tek

Authorized Signature: Rachel Berdunk

DOUGLAS COUNTY PUBLIC WORKS  
2014 COMBINED SIGN BID

3/5/2014

STEEL POSTS

LENGTH	WT./FT.	TYPE	REMARKS	# TO ORDER	UNIT COST	EXTENDED COST
7'	1.12#/FT	STEEL DELINEATOR POST	GREEN ENAMEL	150	\$ 5.53	\$ 829.50-
7'	3#/FT.	STEEL	GREEN ENAMEL	150	\$ 13.86	\$ 2079.00-
8'	3#/FT.	STEEL	GREEN ENAMEL	60	\$ 15.84	\$ 950.40-
10'	3#/FT.	STEEL	GREEN ENAMEL	20	\$ 19.80	\$ 396.00-
TOTAL COST STEEL POSTS						\$ 4254.90 <sup>NP</sup>

TELESPAR POSTS

LENGTH	DIMENSION	TYPE	REMARKS	REMARKS	# TO ORDER	UNIT COST	EXTENDED COST
10'	1-1/2" SQUARE		14 GAUGE	(special order) minimum 25	10	\$	\$
10'	1-3/4" SQUARE		14 GAUGE		100	\$ 22.45	\$ 2245.00-
12'	1-3/4" SQUARE		14 GAUGE		75	\$ 27.00	\$ 2025.00-
3'	2" SQUARE		12 GAUGE	TUBULAR BASE	200	\$ 11.25	\$ 2250.00-
TOTAL COST TELESPAR POSTS						\$ 6520.00 <sup>NP</sup>	NOT COMPLIANT

MISCELLANEOUS ITEMS  
AWARDED ON ITEM BY ITEM BASIS

SIZE	DESCRIPTION	REMARKS	# TO ORDER	UNIT COST	EXTENDED COST	
4" X 50 YD	TEMP. PVMT MARKING TAPE;TY 2, YELLOW	FOILBACK (1 BOX @ 2 ROLLS EACH)	10	\$ ?	\$ ?	
TOTAL MISC. ITEMS						\$ 282.20 <sup>NP</sup>

MUTCD #	SIZE	DESCRIPTION	COLOR	SHEETING	REMARKS	# TO ORDER	UNIT COST	EXTENDED COST
OM3-L	12 X 36	OM3 LEFT RE-FACE	BLACK/YELLOW	TY IV, H/I PRISM.	SHEETING ONLY - NO BLANK	10	\$ 14.11	\$ 141.10-
OM3-R	12 X 36	OM3 RIGHT RE-FACE	BLACK/YELLOW	TY IV, H/I PRISM.	SHEETING ONLY - NO BLANK	10	\$ 14.11	\$ 141.10-

Bid Submitted By: Diana Halliday  
This Tek  
Authorized Signature: Rosche Berglund

3" YELLOW STRIPE (TYPICAL)  
 3 - 9/16" BLACK STRIPE (TYPICAL)

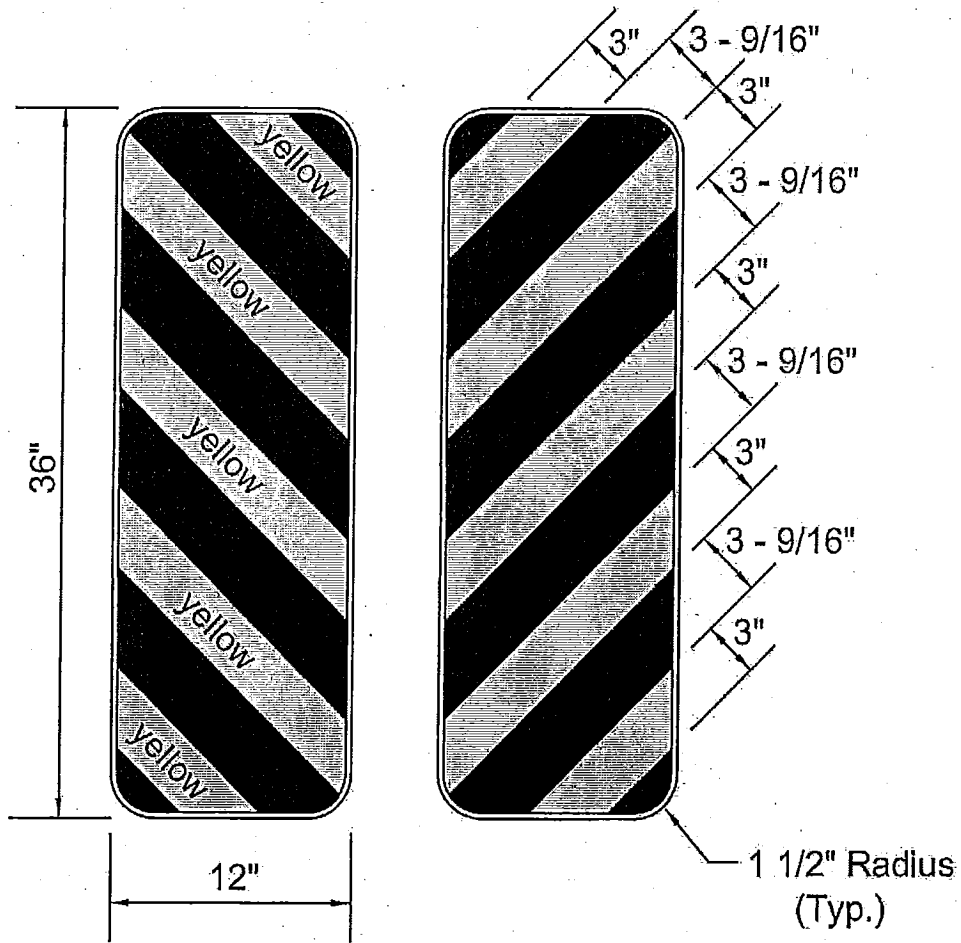

EXAMPLE: OM-3 LEFT AND RIGHT  
 SIZE: 12" X 36", BLACK AND YELLOW  
 STRIPE WIDTH: THE STRIPE WIDTHS SUPPLIED  
 SHOULD CONFORM TO THOSE  
 SPECIFIED ABOVE.

DOUGLAS COUNTY PUBLIC WORKS  
 COMBINED SIGN BID

OM-3  
 LEFT AND RIGHT

Project: OM-3 LEFT AND RIGHT SIGN
Project No: 2024 800
Designed By: HLT
Drawn By: LHL
Checked By: o.s.
Date: 12/2025



Douglas County Public Works  
 1242 Massachusetts  
 Lawrence, Kansas 66064

*J. A. Traffic Pro*

**DOUGLAS COUNTY, KANSAS**

\*\*\*\*\*

FY 2014

**SPECIFICATIONS AND CONTRACT DOCUMENTS**

FOR

**SIGNS AND ACCESSORIES**

**BID NO. 14-F-0002**

\*\*\*\*\*

**DOUGLAS COUNTY, KANSAS**

**SPECIFICATIONS AND CONTRACT DOCUMENTS**

**FOR**

**PUBLIC WORKS DEPARTMENT**

**SIGNS AND ACCESSORIES**

**BID NO. 14-F-0002**

**BY**

**THE DOUGLAS COUNTY COMMISSIONERS**

**Mike Gaughan**  
Member

**Jim Flory**  
Member

**Nancy Thellman**  
Chairman

**Jamie Shew**  
County Clerk

**Keith A. Browning, P.E.**  
Director of Public Works



DOUGLAS COUNTY DEPARTMENT OF PUBLIC WORKS

BID NO. 14-F-0002

**NOTICE TO BIDDERS**

Notice is hereby given that sealed bids for the purchase of SIGNS AND ACCESSORIES, by the Douglas County Public Works Department, will be received in the office of the Douglas County Clerk, 1100 Massachusetts, Courthouse, Lawrence, Kansas, 66044 until 3:15 P.M., Tuesday, April 1, 2014, then publicly opened in the office of the Douglas County Clerk.

Bids must be submitted on forms provided by either the Douglas County Public Works Department, 1242 Massachusetts Street, Lawrence, Kansas or on the Internet at [www.demandstar.com](http://www.demandstar.com). The bids shall be submitted in sealed envelopes, addressed to the Office of the County Clerk, Courthouse, 1100 Massachusetts Street, Lawrence, Kansas 66044, upon which is clearly written or printed "Signs and Accessories", along with the name and address of the bidder. Any bid received by the Office of the County Clerk after the closing date and time will be returned unopened. Faxed bids will not be accepted. Douglas County is not responsible for the lost or misdirected bids, whether lost or misdirected by the postal or courier service of the bidder or the Douglas County mail room.

The awarded bidder shall agree to offer the prices and the terms and conditions herein to other government agencies who wish to participate in a cooperative purchase program with Douglas County. Other agencies will be responsible for entering into separate agreements with the awarded bidder and for all payments thereunder.

The Douglas County Department of Public Works reserves the right to reject any or all bids, or portions of bids, waive technicalities, and to purchase the items, which in the opinion of the Board, are best suited for the use intended.

Dated: March 10, 2014

DEPARTMENT OF PUBLIC WORKS  
DOUGLAS COUNTY, KANSAS  
Keith A. Browning, P.E.  
Director of Public Works

Published: Thursday, March 13, 2014  
Sunday, March 16, 2014

cc: Lawrence Journal World  
Board of County Commissioners  
County Clerk  
County Administrator  
County Shop  
Public Works Accounting  
Purchasing Department  
File

## DOUGLAS COUNTY PUBLIC WORKS DEPARTMENT

### Bid No. 14-F-0002 Signs and Accessories FY 2014

#### Instructions to Bidders

1. It is the intent of Douglas County to purchase the various Signs and Accessories listed in this brochure.
2. Proposals must be submitted on forms provided by either the Douglas County Public Works Department, 1242 Massachusetts Street, Lawrence, Kansas or Demand Star @ www.demandstar.com. Specifications and bid requirements are included in these documents. The proposal must be left intact and will be the only form accepted as a bid by the Board of County Commissioners.
3. Bidders shall show unit prices for each item listed, shall extend all unit prices and total all extensions. All prices shall be F.O.B. Lawrence, Kansas. The County is not subject to City or State Sales Tax.
4. The Devices specified shall conform to the Manual on Uniform Traffic Control Devices, latest edition, as approved by the Federal Highway Administrator as part of the National Standard for all Highways, unless otherwise indicated in the specifications.
5. Bidders shall specify delivery date. Delivery date will be considered, as well as total price, in the selection of the successful bidder. Liquidated damages in the amount of 1% per day of the total bid price of items not received by the specified delivery date will be charged.
6. The supplier must notify Douglas County 48 hours prior to delivery. Douglas County reserves the right to refuse any shipment if proper advance notice is not received.
7. The back face of all finished signs shall be permanently marked with the producers name and year of manufacture. The size of the identification shall be no larger than 4" X 2", unless previously approved by the County Engineer.
8. The awarded bidder shall agree to offer the prices and the terms and conditions offered herein to other governmental agencies who wish to participate in a cooperative purchase program with Douglas County. All other agencies contracting with any vendor shall be responsible for entering into separate agreements and for all payments thereunder.
9. Bids must be sealed and received in the Douglas County Clerk's Office, Douglas County Courthouse, 1100 Massachusetts, Lawrence, Kansas 66044, prior to 3:15 P.M., Tuesday, April 1, 2014. Faxed bids will not be accepted. The County is not responsible for lost or misdirected bids, whether lost or misdirected by the postal or courier service of the bidder or the County mail room. Any bids received after the time specified will be returned unopened.
10. The County reserves the right to reject any or all bids or waive technicalities and to purchase the items which, in the opinion of the Board of County Commissioners, are best suited to the work for which they are intended. The award will be made to the lowest and best bidder for each group of items specified (finished signs, fluorescent signs, cut out lettering, steel posts and telespar posts). Miscellaneous items will be awarded on an item by item basis.

### Instructions to Bidders (continued)

11. All sheeting used on sign faces shall be TYPE IV High Intensity Prismatic Grade or TYPE VIII or better for Fluorescent Orange, Yellow and Yellow/Green sheeting meeting the requirements stated in Section 2201, "Retroreflective Sheeting", of the KDOT Standard Specifications, 2007 Edition, unless otherwise indicated in the bid documents. A copy of this specification is attached to this proposal, or may be viewed at <http://www.ksdot.org/burconsmain/specprov/2007/2201.pdf>. A list of pre-qualified materials can be found at <http://www.ksdot.org/burmatrres/pql/default.asp>.
12. The chip and seal markers shall meet the requirements stated in Special Provision 07-22004 (Temporary Raised Pavement Markers) in Section 2200, "Reflective Materials and Accessory Items", of the KDOT Standard Specifications, 2007 Edition. A copy of this Special Provision is attached to this proposal, or may be viewed at <http://www.ksdot.org/burconsmain/specprov/2007/pdf/07-22004.pdf>.
13. All sign blanks shall be a minimum of .080 gauge aluminum (except those greater than 36" in any dimension, which shall be .10 gauge), unless otherwise specified.

STANDARD TERMS AND CONDITIONS  
DOUGLAS COUNTY, KANSAS

1. **SCOPE:** The following terms and conditions shall prevail unless otherwise modified by Douglas County within this bid document. Douglas County reserves the right to accept or reject any or all bids received, waive technicalities, and to purchase the products, which in the opinion of the Board of County Commissioners, is best suited to the work for which it is intended.
2. **DEFINITIONS AS USED HEREIN:**
  - a. The term "bid request" means a solicitation of a formal sealed bid.
  - b. The term "bid" means the price offered by the bidder.
  - c. The term "bidder" means the offer or vendor.
  - d. The term "County" means Douglas County, Kansas.
  - e. The term "Board of County Commissioners or "BOCC" means the governing body of Douglas County, Kansas.
  - f. The term "awarded bidder" means any bidder awarded a contract pursuant to its bid.
3. **COMPLETING BID:** Bids must be submitted only on the forms (or reproductions thereof) provided in this document. All information must be legible. Any and all corrections and/or erasures must be initialed. Each bid sheet must be signed by the authorized bidder and all required information must be provided.
4. **CONFIDENTIALITY OF BID INFORMATION:** Each bid must be sealed and submitted in an envelope clearly marked "**SIGNS AND ACCESSORIES**" to provide confidentiality of the bid information prior to the bid opening. Supporting documents and/or descriptive literature may be submitted with the bid. Do not indicate bid prices on literature.

All bids and supporting bid documents become public information after the bid opening and are available for public inspection by the general public in accordance with the Kansas Open Records Act.
5. **ACCURACY OF BID:** Each bid is publicly opened in the presence of the Douglas County Clerk. It is required that any and all information presented is accurate and/or will be that by which the bidder will perform if awarded the contract. If there is a discrepancy between the unit price and extended total, the unit price will prevail.
6. **SUBMISSION OF BID:** Bids must be sealed and received in the Douglas County Clerk's Office, Douglas County Courthouse, 1100 Massachusetts, Lawrence, Kansas 66044, prior to 3:15 P.M., Tuesday, April 1, 2014. Faxed bids will not be accepted. The County is not responsible for lost or misdirected bids, whether lost or misdirected by the postal or courier service of the bidder or the County mail room.
7. **ADDENDA:** All changes in connection with this bid will be issued in the form of a written addendum. Signed acknowledgment of receipt of each addendum must be submitted with the bid.

STANDARD TERMS AND CONDITIONS (continued)

8. LATE BIDS, CHANGES OR WITHDRAWALS: Bids received after the deadline designated in this bid document shall not be considered and shall be returned unopened.

Bids may be changed or withdrawn prior to the bid opening. All such transactions must be submitted in writing and received by the County Clerk's Office prior to the bid deadline. Changes or withdrawals may be made after the bid deadline only with the approval of the Board of County Commissioners. After bid opening, no changes in bid prices or other provisions of bids prejudicial to the interest of the County or fair competition shall be permitted.

9. BIDS BINDING: All bids submitted shall be binding upon the bidder if accepted by the County within fifteen (15) calendar days after the bid opening.
10. EQUIVALENT BIDS: When brand or trade names are used in the bid invitation, it is for the purpose of item identification and to establish standards for quality, style and features. Bids on equivalent items of substantially the same quality, style and features are invited unless items are marked "No Substitute." Equivalent bids must be accompanied by descriptive literature and/or specifications to receive consideration. Demonstrations and/or samples may be required and shall be supplied at no charge to the County.
11. NEW MATERIALS, SUPPLIES OR EQUIPMENT: Unless otherwise specified, all materials, supplies or equipment offered by a bidder shall be new, unused, of recent manufacture, first class in every respect and suitable for their intended purpose. All equipment shall be assembled, and ready for operation when delivered.
12. WARRANTY: Supplies or services furnished as a result of this bid shall be covered by the most favorable commercial warranties, expressed or implied, that the bidder and/or manufacturer gives to any customer. The rights and remedies provided herein are in addition to and do not limit any rights afforded to the County by any other clause of this bid. The County reserves the right to request from bidders a separate manufacturer certification of all statements made in the proposal.
13. METHOD OF AWARD AND NOTIFICATION: Bids will be evaluated and the award made to the lowest and best, responsive and responsible bidder(s) whose bid conforms to the specifications and whose bid is considered to be the best value in the opinion of the Board of County Commissioners.

The County reserves the right to accept or reject any or all bids and any part of a bid and to waive informalities, technical defects, and minor irregularities in bids received. **The award will be made to the lowest and best bidder for each group of items specified (finished signs, fluorescent signs, cut out lettering, steel posts and telespar posts). Miscellaneous items will be awarded on an item by item basis.**

The signed bid shall be considered an offer on the part of the bidder; such offer shall be deemed accepted upon issuance by the County of a Purchase Order or other contractual document.

STANDARD TERMS AND CONDITIONS (continued)

14. DELIVERY TERMS: All deliveries shall be F.O.B. Lawrence, Kansas and all freight charges shall be included in the bid price. Delivery date shall be considered as a cost factor in the determination of award.
15. DAMAGED AND/OR LATE SHIPMENTS: The County has no obligation to accept damaged shipments and reserves the right to return at the vendor's expense damaged merchandise even though the damage was not apparent or discovered until after receipt of the items. The Vendor is responsible to notify the Douglas County Department of Public Works of any late or delayed shipments. The County reserves the right to cancel all or any part of an order if the shipment is not made as promised.
16. CREDIT TERMS: Bidder shall indicate all discounts for full and/or prompt payment. Discounts offered shall be computed from date of receipt of correct invoice or receipt and acceptance of products, whichever is later.
17. SELLERS INVOICE: Invoices shall be prepared and submitted in at least two copies to the address shown on the Purchase Order or bid document. Separate invoices are required for each Purchase Order or bid document. Invoices shall contain the following information: Purchase order number and date, bid number, item number, description of supplies or services, sizes, unit of measure, quantity, unit price and extended totals.
18. TAX EXEMPT: The County and its agencies are exempt from State and local sales taxes by K.S.A. 79-3606, as amended. Situs of all transactions under the order(s) that shall be derived from this request shall be deemed to have been accomplished within the State of Kansas.
19. SAFETY: All practices, materials, supplies and equipment shall comply with the Federal Occupational Safety and Health Act, as well as any pertinent Federal, state and/or local safety or environmental codes.
20. DISCLAIMER OF LIABILITY: The County, or any of its agencies, will not hold harmless or indemnify any bidder for any liability whatsoever.
21. HOLD HARMLESS: The awarded bidder agrees to protect, defend, indemnify and hold the Board of County Commissioners, its officers, employees and agents free and harmless from and against any and all losses, penalties, damages, settlements, costs, charges, professional fees or other expenses or liabilities of every kind and character arising out of or relating to any and all claims, liens, demands, obligations, actions, proceedings or causes of action of every kind and character in connection with or arising directly or indirectly out of this agreement and/or the performance hereof. Without limiting the generality of the foregoing, and all such claims, etc., relating to personal injury, infringement of any patent, trademark, copyright (or application for any thereof) or of any other tangible or intangible personal or property right, or actual or alleged violation of any applicable statute, ordinance, administrative order, rule or regulation, or decree of any court, shall be included in the indemnity hereunder. The awarded bidder further agrees to investigate, handle, respond to, provide defense for and defend any such claims, etc., at his/her sole expense and agrees to bear all other costs and expenses related thereto, even if such claim is groundless, false or fraudulent.

STANDARD TERMS AND CONDITIONS (continued)

22. LAW GOVERNING: All contractual agreements shall be subject to, governed by, and construed according to the laws of the State of Kansas.
23. ANTI-DISCRIMINATION CLAUSE: No bidder on this request shall in any way, directly or indirectly, discriminate against any person because of age, race, color, handicap, sex, national origin, or religious creed.

BID  
For  
VARIOUS SIGNS AND ACCESSORIES

**Bid No. 14-F-0002**

Price shall include delivery to the Douglas County Shop, 23rd and Santa Fe Tracks, 711 E 23<sup>rd</sup> St., Lawrence, Kansas.

The Devices specified shall conform to the Manual on Uniform Traffic Control Devices, latest edition, as approved by the Federal Highway Administrator as part of the National Standard for all Highways unless otherwise indicated in the Specifications and Contract Documents.

The Douglas County Public Works 2014 Combined Sign Bid attached hereto is incorporated herein by this reference and is the undersigned bidders bid.

Bids must be returned to the Office of the Douglas County Clerk no later than, 3:15 P.M., Tuesday, April 1, 2014.

**The bidder shall notify Douglas County 48 hours prior to delivery.**

Date available for delivery: 14 DAYS ARO

Bidder: J & A Traffic Products

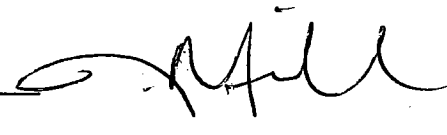
By: JEFF MINDHAM 

Recommended for Approval:

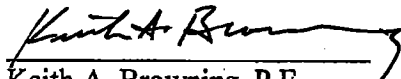
  
Keith A. Browning, P.E.  
Director of Public Works

DOUGLAS COUNTY, KANSAS  
Board of County Commissioners

\_\_\_\_\_  
Nancy Thellman, Chairman

\_\_\_\_\_  
Mike Gaughan, Member

\_\_\_\_\_  
Jim Flory, Member

\_\_\_\_\_  
Date



**SECTION 2201**

**RETROREFLECTIVE SHEETING**

**2201.1 DESCRIPTION**

This specification covers Type I and all Types of High Intensity retroreflective sheeting. This includes both non-exposed glass bead lens and micropismatic sheeting.

**2201.2 REQUIREMENTS**

**a. General.** Provide retroreflective sheeting that complies with ASTM D 4956 (latest revision) except for the color limits as specified in subsection 2201.2b. The type to be provided will be shown in the Contract Documents. Types and classes are as defined in ASTM D 4956.

**b. Color.** The colors of the retroreflective sheeting are white, yellow, red, orange, green, blue, brown, fluorescent orange, fluorescent yellow, and fluorescent yellow-green. Provide colors that comply with the chromaticity limits as shown in TABLE 2201-1 for both Type I and Type III sheeting and TABLE 2201-2 for all other Types of High Intensity sheeting (Type IV through Type XI). Provide fluorescent colors that comply with the chromaticity limits in ASTM D 4956 (latest revision).

TABLE 2201-1: COLOR SPECIFICATION (Type I and Type III)								
COLOR	Chromaticity Coordinates							
	1		2		3		4	
	x	y	x	y	x	y	x	y
White	0.310	0.313	0.338	0.342	0.325	0.355	0.300	0.327
Yellow	0.496	0.503	0.545	0.454	0.505	0.433	0.460	0.474
Red	0.574	0.337	0.665	0.345	0.708	0.292	0.613	0.297
Orange	0.558	0.352	0.636	0.364	0.570	0.429	0.506	0.404
Green	0.130	0.387	0.180	0.410	0.140	0.521	0.098	0.490
Blue	0.138	0.065	0.112	0.135	0.160	0.170	0.176	0.120
Brown	0.430	0.340	0.610	0.390	0.550	0.450	0.430	0.390

TABLE 2201-2: COLOR SPECIFICATION (Type IV - Type XI)								
COLOR	Chromaticity Coordinates							
	1		2		3		4	
	x	y	x	y	x	y	x	y
White	0.310	0.313	0.328	0.331	0.316	0.345	0.300	0.327
Yellow	0.515	0.484	0.545	0.454	0.505	0.433	0.475	0.460
Red	0.586	0.324	0.664	0.336	0.708	0.292	0.613	0.297
Orange	0.558	0.352	0.636	0.364	0.570	0.429	0.506	0.404
Green	0.130	0.387	0.180	0.410	0.155	0.478	0.107	0.457
Blue	0.138	0.065	0.112	0.135	0.160	0.170	0.176	0.120
Brown	0.430	0.340	0.610	0.390	0.550	0.450	0.430	0.390

**c. Conformable Retroreflective Sheeting.** Provide High Intensity retroreflective sheeting that has a conformable aluminum foil backing with an aggressive pressure sensitive adhesive. This material is designed for application to moderately rough or porous metal, wood or masonry surfaces. Provide material that complies with ASTM D 4956 (latest revision) with the following exceptions and additions:

- (1) Conformable aluminum backing thickness – 0.005 inches to 0.010 inches.
- (2) Follow all manufacturers' recommendations for application procedures and temperatures.

**2201.3 MANUFACTURER WARRANTY**

The following warranty conditions apply only to the retroreflective sheeting manufacturer. Provide a product warranty for a minimum period of 10 years on all Types of High Intensity retroreflective sheeting, for placement on permanent signing. Failure to comply with this warranty may be cause for removal from the prequalified list.

The High Intensity retroreflective sheeting warranty must comply with the following requirements and obligations:

- Certification: Submit with each lot or shipment, a certification which states that the material supplied is subject to and complies with the requirements. Include in the certification, the manufacturer's office, address, phone number and the contact for potential claims under the provisions of this warranty. Provide documentation as to which signs were fabricated from each lot.
- Field Performance: Field Performance applies to retroreflective sheeting applied to sign blank materials or overlaid on existing signs. The field performance obligation period begins with the date of erection. The sheeting is considered unsatisfactory if it has deteriorated due to natural causes to the extent that the sign is ineffective for its intended purpose when viewed from a moving vehicle under normal day and night driving conditions or shows any of the following defects:
  - Cracking discernible with the unaided eye from a driver's position at a distance of 50 feet or greater from the sign;
  - More than 25% loss of specular gloss and cracking, scaling, pitting, orange peel, delamination, edge lifting or curling;
  - Peeling in excess of 3/8 inch;
  - Shrinkage in excess of 3/16 inch total per yard of sheeting width;
  - Fading or loss of color to the extent that retroreflective sheeting color fails to comply with the subsection 2201.2b., or;
  - Loss of retroreflectivity reducing the coefficient of retroreflection as measured by a retroreflectometer to less than the minimum specified in TABLE 2201-3 at 0.2° observation and -4° entrance angles. Make all measurements after cleaning the sign.

<b>TABLE 2201-3: MINIMUM COEFFICIENT OF RETROREFLECTION CANDELAS PER SQUARE METER PER LUX</b>	
Sheeting Color	Min. Coefficient
White	200
Yellow	136
Green	36
Red	36
Blue	16
Brown	9

**Defective Material Replacement:** When traffic signs with High Intensity sheeting fail to comply with the field performance requirements, re-sheet or replace the signs at no cost to the Douglas County for materials and labor. Employ a contractor qualified by the KDOT to perform signing work. Install highway signs, as shown in the Contract Documents and the M.U.T.C.D. (latest edition) and provide proper traffic control.

Replace all defective material within 60 days after written notification by Douglas County. Signs not corrected within 60 days, will be removed and replaced by Douglas County. Signs removed by Douglas County will be placed in storage for inspections by the manufacturer, and the manufacturer will be billed for all costs of replacement of the sheeting.

When more than 25% of the signs within a lot fail to comply with the requirements, replace all signs made from that lot.

#### **2201.4 PREQUALIFICATION**

Manufacturers desiring to provide material under this specification are to submit prequalification samples of each type, class and color covered by this specification which they wish to prequalify. Each sample consists of 3 pieces 24 inches square.

Forward the prequalification samples to the Engineer of Tests, Materials and Research Center, 2300 Van Buren, Topeka, KS 66611. Samples will be tested for compliance with all requirements of this specification. Each Manufacturer will be notified of the test results.

If the prequalification samples of retroreflective sheeting comply with this specification, the product will be placed on a list of prequalified products maintained by the Bureau of Materials and Research. No retroreflective sheeting will be used on KDOT projects unless it has been prequalified. Manufacturers will be required to requalify at intervals determined by the Engineer of Tests.

Testing and evaluation by KDOT may be waived if complete testing has been performed on the identical product by AASHTO National Transportation Product Evaluation Program (NTPEP). Forward an official copy of the test report along with evidence that the product referenced is identical to that submitted for prequalification, to the Engineer of Tests for evaluation.

#### **2201.5 METHODS OF TESTS**

All tests will be conducted in accordance with ASTM D 4956 with the exception of artificial weathering. Artificial weathering will be conducted according to ASTM G 155, Cycle 1, with the following additions and exceptions:

- At the end of each 20 hour cycle, the panels will be placed in a cold cabinet at approximately 0°F for one hour. After removal from the cold cabinet, panels will be returned to the weatherometer to await the start of the next cycle.
- Water used in the weatherometer will be city water softened to a total hardness content of less than 5 parts per million expressed as calcium carbonate.

#### **2201.6 BASIS OF ACCEPTANCE**

##### **a. Permanent Sheeting.**

- (1) Prequalification as required by subsection 2201.4.
- (2) Satisfactory results of tests conducted at MRC. Each lot of sheeting will be sampled at destination by a representative of the KDOT and will be subjected to a visual examination and tested for physical properties as necessary to verify that the sheeting complies with this specification.
- (3) Receipt of the warranty certification as specified in subsection 2201.3 by the County Engineer.

**b. Temporary Sheeting.** Retroreflective sheeting used to manufacture temporary traffic control signs will be accepted on the basis of a certification prepared by the contractor stating that the retroreflective sheeting used to manufacture the signs was prequalified under this specification, and visual inspection by the Engineer for condition and other requirements.

**KANSAS DEPARTMENT OF TRANSPORTATION  
SPECIAL PROVISION TO THE  
STANDARD SPECIFICATIONS, EDITION 2007**

Add a new SECTION in DIVISION 2200:

**TEMPORARY RAISED PAVEMENT MARKERS**

**1.0 DESCRIPTION**

This specification covers temporary raised pavement markers for lane marking and delineation. This includes both Flexible and Rigid (Types I and II) markers for use on both Portland cement concrete and asphalt surfaces.

**2.0 REQUIREMENTS**

**a. General.**

(1) Provide temporary reflective markers as shown in the Contract Documents. The markers shall be readily visible at night, from a minimum of 300 feet, when viewed with high beam automobile headlamps. Prior to use, markers must be approved by the Engineer. The marker shall be the same color as the reflective elements. All markers shall be capable of sustaining 2000 direct wheel-over impacts at 60 mph without losing adhesion to the roadway or sustaining damage to the marker body.

(2) Provide Flexible temporary raised pavement markers which consist of an L-shaped flexible polyurethane body with prismatic reflective sheeting on both faces. The reflective sheeting shall be a minimum of 1 square inch spread over the 4" wide marker. The markers shall have minimum dimensions of 4 inches wide x 2 inches high with a 1 inch wide base leg. Thickness of the body shall be a minimum of 0.06 inches. The marker shall have an affixed pressure sensitive adhesive, protected by a release paper, for application to the pavement surface. Attach a clear flexible plastic cover to the vertical section of the marker to protect the reflective material during surfacing operations. The cover shall withstand the work and be easily removed after the operation. The markers shall not cause any damage to the automobile.

(3) Provide Rigid (Type I) temporary raised pavement markers constructed of traffic bearing high impact plastic with prismatic reflective faces. The base of the markers shall have minimum dimensions of 2.5 inches wide, 4 inches long and 0.4 inches high. The base of the marker shall be flat. Markers shall be reflectorized with one or more reflective faces on each side using either an acrylic retroreflector, or retroreflective sheeting. Each face shall contain a minimum of 0.38 square inches of reflective surface. The adhesive used shall not stain the pavement and will allow the markers to be easily removed without damage to the roadway surface. If the marker is self adhesive, it shall be pre-coated with an affixed pressure sensitive adhesive, protected by a release paper.

(4) Provide Rigid (Type II) or brick markers constructed of traffic bearing high impact plastic with prismatic reflective faces. The marker shall have minimum dimensions of 2.5 inches high, 7.5 inches wide and 13 inches long. The base of the marker shall be flat. Markers shall be reflectorized with two or more reflective faces on each side using either an acrylic retroreflector, or retroreflective sheeting. Each face shall contain a minimum of 3.75 square inches of reflective surface. The adhesive used will allow the markers to be removed without damage to the roadway surface. If the marker is self adhesive, it shall be pre-coated with an affixed pressure sensitive adhesive, protected by a release paper.

**b. Retroreflectivity.** Provide markers in white or yellow which comply with the minimum requirements shown in TABLE 1:

<b>TABLE 1: RETROREFLECTIVITY REQUIREMENTS</b>	
<b>Color</b>	<b>Millicandelas/sq m/lux (min.)<sup>a</sup> (measured at 0.2° observation angle and 0° entrance angle)</b>
<b>White</b>	<b>3.0</b>
<b>Yellow</b>	<b>1.8</b>

<sup>a</sup> Flexible markers must meet these requirements before and after durability testing

c. **Color.** Markers shall be white or yellow in color, solid throughout, and match the color of the lane line on which the marker will be placed under both daylight and nighttime conditions.

d. **Durability.** Flexible markers, as defined in subsection 2.0a.(2), must withstand 2000 revolutions on a small-wheel circular track. 12 markers of each color will be tested. No more than 3 markers shall move from their original position during testing.

### **3.0 TEST METHODS**

a. **Retroreflectivity.** Test in accordance with ASTM E 809.

b. **Durability.** Test in accordance with ASTM E 660, with the following variations:

(1) Mount two opposite wheels with 11 x 6.00 x 5 nylon smooth non-pattern tread tires with a total load of 50 pounds on each tire. Maintain tire pressure at 25 psi. Mount the wheels perpendicular to the specimens and toe out 2° to produce a slight abrading action.

(2) Apply markers, according to the manufacturer's recommendations, to 6 inch diameter dense grade asphalt concrete cores, which have been compacted at 3000 psi for 2 minutes.

### **4.0 PREQUALIFICATION**

Manufacturers wishing to supply markers to KDOT projects must have their product tested by the AASHTO National Transportation Product Evaluation Program (NTPEP). Submit 12 flexible markers or 2 rigid markers of each color for which prequalification is requested, and an official copy of the NTPEP test report to the Engineer of Tests, Materials and Research Center, 2300 Van Buren, Topeka, KS 66611. Include evidence that the product offered is identical to that described in the test report, and information regarding the recommended adhesive, if any is required. Prequalification will be based on satisfactory compliance of NTPEP results and laboratory testing with subsection 2.0.

### **5.0 BASIS OF ACCEPTANCE**

Prequalification as required by subsection 4.0.

Receipt and approval of a Type C certification as specified in DIVISION 2600.

Visual inspection for condition and dimensional requirements.

09-06-12 M&R (SML/KJS)  
Jan-13 Letting

74 R

DOUGLAS COUNTY PUBLIC WORKS  
2014 COMBINED SIGN BID

3/5/2014

FINISHED SIGNS

MUTCD #	SIZE	DESCRIPTION	COLOR	SHEETING	REMARKS	# TO ORDER	UNIT COST	EXTENDED COST
M1-6	24 X 24	DOUGLAS COUNTY	YELLOW/BLUE	TY IV, H/I PRISM.	NO ROUTE NUMBER	10	\$	\$
M1-6	24 X 24	DOUGLAS COUNTY 1	YELLOW/BLUE	TY IV, H/I PRISM.	ROUTE MARKER	4	\$	\$
M1-6	24 X 24	DOUGLAS COUNTY 1S	YELLOW/BLUE	TY IV, H/I PRISM.	ROUTE MARKER	5	\$	\$
M1-6	24 X 24	DOUGLAS COUNTY 1W	YELLOW/BLUE	TY IV, H/I PRISM.	ROUTE MARKER	5	\$	\$
M1-6	24 X 24	DOUGLAS COUNTY 1E	YELLOW/BLUE	TY IV, H/I PRISM.	ROUTE MARKER	5	\$	\$
M1-6	24 X 24	DOUGLAS COUNTY 2	YELLOW/BLUE	TY IV, H/I PRISM.	ROUTE MARKER	5	\$	\$
M1-6	24 X 24	DOUGLAS COUNTY 3	YELLOW/BLUE	TY IV, H/I PRISM.	ROUTE MARKER	5	\$	\$
M1-6	24 X 24	DOUGLAS COUNTY 4	YELLOW/BLUE	TY IV, H/I PRISM.	ROUTE MARKER	4	\$	\$
M1-6	24 X 24	DOUGLAS COUNTY 6	YELLOW/BLUE	TY IV, H/I PRISM.	ROUTE MARKER	10	\$	\$
M1-6	24 X 24	DOUGLAS COUNTY 438	YELLOW/BLUE	TY IV, H/I PRISM.	ROUTE MARKER	7	\$	\$
M1-6	24 X 24	DOUGLAS COUNTY 442	YELLOW/BLUE	TY IV, H/I PRISM.	ROUTE MARKER	5	\$	\$
M1-6	24 X 24	DOUGLAS COUNTY 460	YELLOW/BLUE	TY IV, H/I PRISM.	ROUTE MARKER	10	\$	\$
M1-6	24 X 24	DOUGLAS COUNTY 1023	YELLOW/BLUE	TY IV, H/I PRISM.	ROUTE MARKER	10	\$	\$
M1-6	24 X 24	DOUGLAS COUNTY 1029	YELLOW/BLUE	TY IV, H/I PRISM.	ROUTE MARKER	10	\$	\$
M1-6	24 X 24	DOUGLAS COUNTY 1039	YELLOW/BLUE	TY IV, H/I PRISM.	ROUTE MARKER	7	\$	\$
M4-6	24 X 12	"END" - AUXILIARY SIGN	BLACK/WHITE	TY IV, H/I PRISM.		5	\$	\$
M6-1	21 X 15	DIRECTIONAL SIGN	BLACK/WHITE	TY IV, H/I PRISM.		10	\$	\$
OM2-2V	6 X 12	TYPE 2 OBJECT MARKER	YELLOW	TY IV, H/I PRISM.		400	\$	\$
OM2-2V	6 X 12	TYPE 2 OBJECT MARKER	WHITE	TY IV, H/I PRISM.		50	\$	\$
OM3-L	12 X 36	OBJECT MARKER TYPE III - LEFT	BLACK/YELLOW	TY IV, H/I PRISM.	SEE PLAN DETAILS	254	\$	\$
OM3-R	12 X 36	OBJECT MARKER TYPE III - RIGHT	BLACK/YELLOW	TY IV, H/I PRISM.	SEE PLAN DETAILS	250	\$	\$
OM4-3	18 X 18	END OF ROAD MARKER	RED	TY IV, H/I PRISM.		24	\$	\$
R1-1	30 X 30	STOP SIGN	WHITE/RED	TY IV, H/I PRISM.		20	\$	\$
R1-2	30 X 30 X 30	YIELD	WHITE/RED	TY IV, H/I PRISM.		1	\$	\$
R1-3P	18 X 6	ALL WAY	WHITE/RED	TY IV, H/I PRISM.		8	\$	\$
R2-1	24 X 30	"SPEED LIMIT"	BLACK/WHITE	TY IV, H/I PRISM.	NO SPEED LIMIT NUMBER	7	\$	\$
R2-1-25	24 X 30	"SPEED LIMIT 25"	BLACK/WHITE	TY IV, H/I PRISM.		4	\$	\$
R2-1-40	24 X 30	"SPEED LIMIT 40"	BLACK/WHITE	TY IV, H/I PRISM.		5	\$	\$
R2-1-55	24 X 30	"SPEED LIMIT 55"	BLACK/WHITE	TY IV, H/I PRISM.		20	\$	\$
R5-1	30 X 30	"DO NOT ENTER"	WHITE/RED	TY IV, H/I PRISM.		2	\$	\$
R7-1	12 X 18	NO PARKING <—>	WHITE/RED	TY IV, H/I PRISM.	DOUBLE ARROW BELOW "NO PARKING"	5	\$	\$
R7-1	18 x 24	NO PARKING <—>	WHITE/RED	TY IV, H/I PRISM.	DOUBLE ARROW BELOW "NO PARKING"	4	\$	\$
R7-1L	12 x 18	NO PARKING <—	WHITE/RED	TY IV, H/I PRISM.	LEFT ARROW BELOW "NO PARKING"	4	\$	\$
R7-1L	18 x 24	NO PARKING <—	WHITE/RED	TY IV, H/I PRISM.	LEFT ARROW BELOW "NO PARKING"	7	\$	\$
R7-1R	12 x 18	NO PARKING —>	WHITE/RED	TY IV, H/I PRISM.	RIGHT ARROW BELOW "NO PARKING"	5	\$	\$
R7-1R	18 x 24	NO PARKING —>	WHITE/RED	TY IV, H/I PRISM.	RIGHT ARROW BELOW "NO PARKING"	2	\$	\$
R11-2	48 X 30	"ROAD CLOSED"	BLACK/WHITE	TY IV, H/I PRISM.	2 LINES	7	\$	\$
R11-3a	60 X 30	"ROAD CLOSED ___ MILES AHEAD LOCAL TRAFFIC ONLY"	BLACK/WHITE	TY IV, H/I PRISM.	3 LINES	4	\$	\$
R12-1	24 X 30	"WEIGHT LIMIT ___ TONS"	BLACK/WHITE	TY IV, H/I PRISM.		5	\$	\$
R12-5	24 X 36	"WEIGHT LIMIT ___ TONS"	BLACK/WHITE	TY IV, H/I PRISM.	3 TIER W/ NO DISPLAYED # - "T" ONLY	10	\$	\$

SUBTOTAL FINISHED SIGNS

Bid Submitted By:

J & A Traffic Products

Authorized Signatures:

*[Signature]*

79 8

DOUGLAS COUNTY PUBLIC WORKS  
2014 COMBINED SIGN BID

3/5/2014

FINISHED SIGNS (CONTINUED)

MUTCD #	SIZE	DESCRIPTION	COLOR	SHEETING	REMARKS	# TO ORDER	UNIT COST	EXTENDED COST
W1-1L	30 X 30	LEFT TURN ARROW	BLACK/YELLOW	TY IV, H/I PRISM.		4	\$	\$
W1-1L	48 X 48	LEFT TURN ARROW	BLACK/YELLOW	TY IV, H/I PRISM.		2	\$	\$
W1-1R	36 X 36	RIGHT TURN ARROW	BLACK/YELLOW	TY IV, H/I PRISM.		4	\$	\$
W1-1R	48 X 48	RIGHT TURN ARROW	BLACK/YELLOW	TY IV, H/I PRISM.		3	\$	\$
W1-2L	30 X 30	CURVE SIGN - LEFT	BLACK/YELLOW	TY IV, H/I PRISM.		2	\$	\$
W1-2L	36 X 36	CURVE SIGN - LEFT	BLACK/YELLOW	TY IV, H/I PRISM.		3	\$	\$
W1-2L	48 X 48	CURVE SIGN - LEFT	BLACK/YELLOW	TY IV, H/I PRISM.		2	\$	\$
W1-2R	30 X 30	CURVE SIGN - RIGHT	BLACK/YELLOW	TY IV, H/I PRISM.		5	\$	\$
W1-2R	36 X 36	CURVE SIGN - RIGHT	BLACK/YELLOW	TY IV, H/I PRISM.		4	\$	\$
W1-3R	30 X 30	REVERSE TURN SIGN - RIGHT	BLACK/YELLOW	TY IV, H/I PRISM.		1	\$	\$
W1-6	36 X 18	ONE-DIRECTION LARGE ARROW	BLACK/YELLOW	TY IV, H/I PRISM.		4	\$	\$
W1-6	48 X 24	ONE-DIRECTION LARGE ARROW	BLACK/YELLOW	TY IV, H/I PRISM.		3	\$	\$
W1-7	36 X 18	TWO-DIRECTION LARGE ARROW	BLACK/YELLOW	TY IV, H/I PRISM.		3	\$	\$
W1-7	48 X 24	TWO-DIRECTION LARGE ARROW	BLACK/YELLOW	TY IV, H/I PRISM.		5	\$	\$
W1-8	18 X 24	CHEVRON ALIGNMENT SIGN	BLACK/YELLOW	TY IV, H/I PRISM.		60	\$	\$
W2-4	30 X 30	T-INTERSECTION AHEAD	BLACK/YELLOW	TY IV, H/I PRISM.		3	\$	\$
W3-5	36 X 36	REDUCE SPEED LIMIT AHEAD 30	BL-WHITE/YELLOW	TY IV, H/I PRISM.		4	\$	\$
W3-5	36 X 36	REDUCE SPEED LIMIT AHEAD 40	BL-WHITE/YELLOW	TY IV, H/I PRISM.		5	\$	\$
W8-6	30 X 30	TRUCK CROSSING	BLACK/YELLOW	TY IV, H/I PRISM.		4	\$	\$
W8-17	30 X 30	SHOULDER DROP OFF (SYMBOL)	BLACK/YELLOW	TY IV, H/I PRISM.		7	\$	\$
W10-1	36" DIA	GRADE CROSSING ADVANCE WARNING	BLACK/YELLOW	TY IV, H/I PRISM.	(RAILROAD EMBLEM)	6	\$	\$
W11-8	36 X 36	EMERGENCY VEHICLE	BLACK/YELLOW	TY IV, H/I PRISM.		5	\$	\$
W11-8P	24 X 18	"FIRE STATION"	BLACK/YELLOW	TY IV, H/I PRISM.	TWO LINES	4	\$	\$
W13-1P	18 X 18	"20 MPH"	BLACK/YELLOW	TY IV, H/I PRISM.		5	\$	\$
W13-1P	18 X 18	"35 MPH"	BLACK/YELLOW	TY IV, H/I PRISM.		5	\$	\$
W13-1P	24 X 24	"45 MPH"	BLACK/YELLOW	TY IV, H/I PRISM.		6	\$	\$
W14-1	30 X 30	"DEAD END"	BLACK/YELLOW	TY IV, H/I PRISM.		5	\$	\$
W14-2	30 X 30	"NO OUTLET"	BLACK/YELLOW	TY IV, H/I PRISM.	DIAMOND SHAPE	6	\$	\$
W14-3	48 X 48 X 36	"NO PASSING ZONE" PENNANT	BLACK/YELLOW	TY IV, H/I PRISM.	2 HOLES FOR 1 POST MOUNT	20	\$	\$
W16-2P	18 X 12	"500 FEET" PLAQUE	BLACK/YELLOW	TY IV, H/I PRISM.		12	\$	\$
W20-3	30 X 30	ROAD CLOSED	BLACK/YELLOW	TY IV, H/I PRISM.		6	\$	\$
N/A	30 X 30	"FLOOD AREA AHEAD"	BLACK/YELLOW	TY IV, H/I PRISM.	DIAMOND SHAPE	4	\$	\$
SUBTOTAL FINISHED SIGNS							\$	\$
TOTAL COST FINISHED SIGNS							\$	\$

Bid Submitted By:

JSA Traffic Products

Authorized Signature:

*[Handwritten Signature]*

*Handwritten initials/signature*

DOUGLAS COUNTY PUBLIC WORKS  
2014 COMBINED SIGN BID

3/5/2014

FLUORESCENT SIGNS

MUTCD #	SIZE	DESCRIPTION	COLOR	SHEETING	REMARKS	# TO ORDER	UNIT COST	EXTENDED COST
M4-8	24 X 12	DETOUR	FLUORESCENT ORANGE	TY VIII OR BETTER		21	\$	\$
M4-8a	24 X 18	END DETOUR	FLUORESCENT ORANGE	TY VIII OR BETTER		4	\$	\$
M4-10L	48 X 18	DETOUR ARROW - LEFT	FLUORESCENT ORANGE	TY VIII OR BETTER		2	\$	\$
M4-10R	48 X 18	DETOUR ARROW - RIGHT	FLUORESCENT ORANGE	TY VIII OR BETTER		2	\$	\$
S3-1	30 X 30	SCHOOL BUS STOP AHEAD	FLUOR. YELLOW/GREEN	TY VIII OR BETTER	FLUORESCENT YEL/GREEN	4	\$	\$
W1-7	60 X 30	TWO-DIRECTION LARGE ARROW	FLUORESCENT YELLOW	TY VIII OR BETTER	FLUORESCENT YELLOW	4	\$	\$
W8-1	36 X 36	BUMP	FLUORESCENT ORANGE	TY VIII OR BETTER		5	\$	\$
W8-4	36 X 36	SOFT SHOULDER	FLUORESCENT ORANGE	TY VIII OR BETTER		6	\$	\$
W8-8	36 X 36	ROUGH ROAD	FLUORESCENT ORANGE	TY VIII OR BETTER		1	\$	\$
W8-9	36 X 36	LOW SHOULDER	FLUORESCENT ORANGE	TY VIII OR BETTER		8	\$	\$
W8-11	36 X 36	UNEVEN LANES	FLUORESCENT ORANGE	TY VIII OR BETTER		8	\$	\$
W20-1	36 X 36	ROAD WORK AHEAD	FLUORESCENT ORANGE	TY VIII OR BETTER		21	\$	\$
W20-1	48 X 48	ROAD WORK AHEAD	FLUORESCENT ORANGE	TY VIII OR BETTER		4	\$	\$
W20-2	48 X 48	DETOUR AHEAD	FLUORESCENT ORANGE	TY VIII OR BETTER		6	\$	\$
W20-2	48 X 48	DETOUR 500 FT	FLUORESCENT ORANGE	TY VIII OR BETTER		4	\$	\$
W20-3	48 X 48	"ROAD CLOSED"	FLUORESCENT ORANGE	TY VIII OR BETTER	2 LINES	4	\$	\$
W20-3	48 X 48	ROAD CLOSED 500 FT	FLUORESCENT ORANGE	TY VIII OR BETTER		5	\$	\$
W20-4	36 X 36	"ONE LANE ROAD AHEAD"	FLUORESCENT ORANGE	TY VIII OR BETTER	3 LINES	14	\$	\$
W21-5	36 X 36	SHOULDER WORK	FLUORESCENT ORANGE	TY VIII OR BETTER		8	\$	\$
N/A	48 X 48	"TRUCKS TURNING"	FLUORESCENT ORANGE	TY VIII OR BETTER	2 LINES	4	\$	\$
TOTAL COST FLUORESCENT SIGNS								\$

CUT OUT LETTERING

SERIES	SIZE	DESCRIPTION	CHARACTERS	COLOR	SHEETING	REMARKS	# TO ORDER (PKG)*	UNIT COST	EXTENDED COST
SERIES D	10"	NUMBER "1"	25	BLACK	TY IV, H/I PRISM.	PRESSURE SENSITIVE	1	\$	\$
SERIES D	10"	NUMBER "4"	25	BLACK	TY IV, H/I PRISM.	PRESSURE SENSITIVE	1	\$	\$
SERIES C	8"	NUMBER "4"	25	YELLOW	TY IV, H/I PRISM.	PRESSURE SENSITIVE	1	\$	\$
TOTAL COST CUT OUT LETTERING								\$	

\* NOTE: \*ASSUMING EACH PACKAGE CONTAINS 25 CHARACTERS

Bid Submitted By: *JSA Traffic Products*  
Authorized Signature: *[Signature]*



DOUGLAS COUNTY PUBLIC WORKS  
2014 COMBINED SIGN BID

3/5/2014

*Handwritten initials/signature*

STEEL POSTS

LENGTH	WT./FT.	TYPE	REMARKS	# TO ORDER	UNIT COST	EXTENDED COST
7'	1.12#/FT	STEEL DELINEATOR POST	GREEN ENAMEL	150	\$ <i>MIB</i>	\$ <i>MIB</i>
7'	3#/FT.	STEEL	GREEN ENAMEL	150	\$ <i>MIB</i>	\$ <i>MIB</i>
8'	3#/FT.	STEEL	GREEN ENAMEL	60	\$ <i>MIB</i>	\$ <i>MIB</i>
10'	3#/FT.	STEEL	GREEN ENAMEL	20	\$ <i>MIB</i>	\$ <i>MIB</i>
TOTAL COST STEEL POSTS						\$ <u>          </u>

TELESPAR POSTS

LENGTH	DIMENSION	TYPE	REMARKS	# TO ORDER	UNIT COST	EXTENDED COST
10'	1-1/2" SQUARE		14 GAUGE	10	\$ 14.00	\$ 140.00
10'	1-3/4" SQUARE		14 GAUGE	100	\$ 15.50	\$ 1,550.00
12'	1-3/4" SQUARE		14 GAUGE	75	\$ 18.60	\$ 1,395.00
3'	2" SQUARE		12 GAUGE	200	\$ 7.80	\$ 1,560.00
TOTAL COST TELESPAR POSTS						\$ <i>4,645.00</i>

MISCELLANEOUS ITEMS  
AWARDED ON ITEM BY ITEM BASIS

SIZE	DESCRIPTION	REMARKS	# TO ORDER	UNIT COST	EXTENDED COST
4" X 50 YD	TEMP. PVMT MARKING TAPE;TY 2, YELLOW	FOILBACK (1 BOX @ 2 ROLLS EACH)	10	\$ <i>MIB</i>	\$ <u>          </u>

MUTCD #	SIZE	DESCRIPTION	COLOR	SHEETING	REMARKS	# TO ORDER	UNIT COST	EXTENDED COST
OM3-L	12 X 36	OM3 LEFT RE-FACE	BLACK/YELLOW	TY IV, H/I PRISM.	SHEETING ONLY - NO BLANK	10	\$ <i>MIB</i>	\$ <i>MIB</i>
OM3-R	12 X 36	OM3 RIGHT RE-FACE	BLACK/YELLOW	TY IV, H/I PRISM.	SHEETING ONLY - NO BLANK	10	\$ <i>MIB</i>	\$ <i>MIB</i>
TOTAL MISC. ITEMS								\$ <u>          </u>

Bid Submitted By:

*JIA TRAPP Producers*

Authorized Signature:

*[Handwritten Signature]*

**3" YELLOW STRIPE (TYPICAL)  
3 - 9/16" BLACK STRIPE (TYPICAL)**

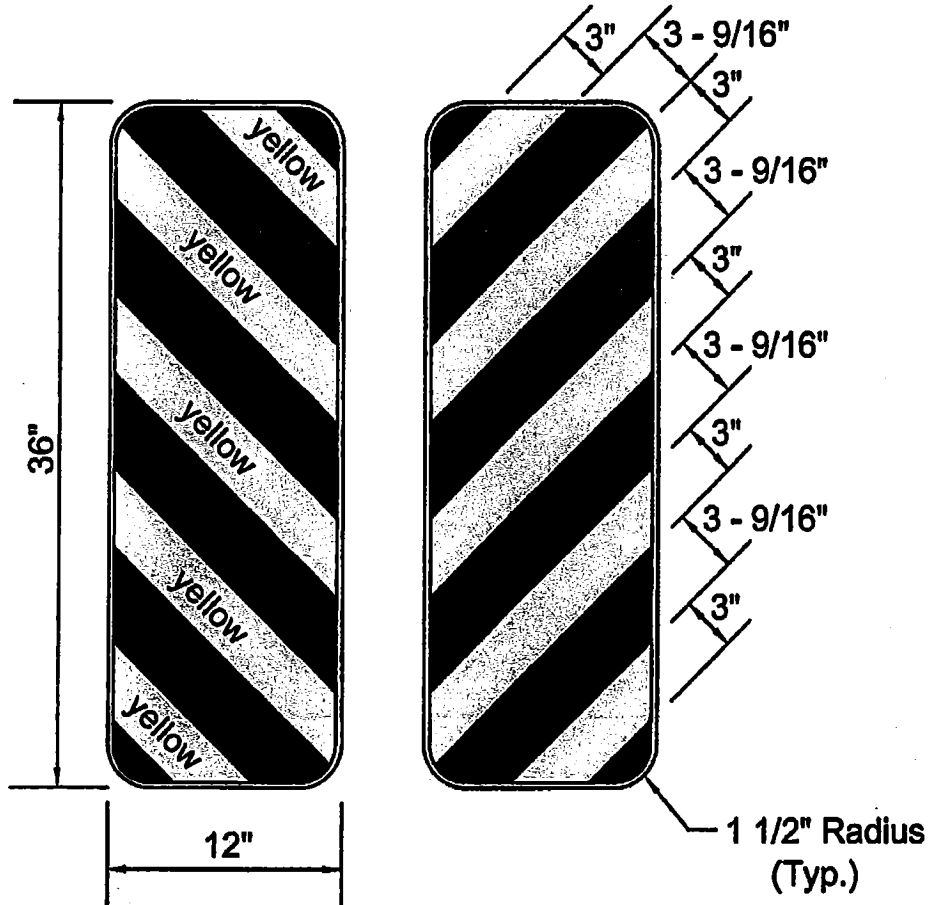

**EXAMPLE: OM-3 LEFT AND RIGHT  
SIZE: 12" X 36", BLACK AND YELLOW  
STRIPE WIDTH: THE STRIPE WIDTHS SUPPLIED  
SHOULD CONFORM TO THOSE  
SPECIFIED ABOVE.**

DOUGLAS COUNTY PUBLIC WORKS  
COMBINED SIGN BID

OM-3  
LEFT AND RIGHT

Project	OM-3 LEFT AND RIGHT SIGN
Project No.	001120
Contract No.	204
Drawn by	LJA
Checked by	g.s.
Date	07/2000



Douglas County Public Works  
1242 Massachusetts  
Lawrence, Kansas 66044

*OSburn Associate*

**DOUGLAS COUNTY, KANSAS**

\*\*\*\*\*

FY 2014

**SPECIFICATIONS AND CONTRACT DOCUMENTS**

FOR

**SIGNS AND ACCESSORIES**

**BID NO. 14-F-0002**

\*\*\*\*\*

**DOUGLAS COUNTY, KANSAS**

**SPECIFICATIONS AND CONTRACT DOCUMENTS**

**FOR**

**PUBLIC WORKS DEPARTMENT**

**SIGNS AND ACCESSORIES**

**BID NO. 14-F-0002**

**BY**

**THE DOUGLAS COUNTY COMMISSIONERS**

**Mike Gaughan**  
Member

**Jim Flory**  
Member

**Nancy Thellman**  
Chairman

**Jamie Shew**  
County Clerk

**Keith A. Browning, P.E.**  
Director of Public Works

DOUGLAS COUNTY DEPARTMENT OF PUBLIC WORKS

BID NO. 14-F-0002

**NOTICE TO BIDDERS**

Notice is hereby given that sealed bids for the purchase of SIGNS AND ACCESSORIES, by the Douglas County Public Works Department, will be received in the office of the Douglas County Clerk, 1100 Massachusetts, Courthouse, Lawrence, Kansas, 66044 until 3:15 P.M., Tuesday, April 1, 2014, then publicly opened in the office of the Douglas County Clerk.

Bids must be submitted on forms provided by either the Douglas County Public Works Department, 1242 Massachusetts Street, Lawrence, Kansas or on the Internet at [www.demandstar.com](http://www.demandstar.com). The bids shall be submitted in sealed envelopes, addressed to the Office of the County Clerk, Courthouse, 1100 Massachusetts Street, Lawrence, Kansas 66044, upon which is clearly written or printed "Signs and Accessories", along with the name and address of the bidder. Any bid received by the Office of the County Clerk after the closing date and time will be returned unopened. Faxed bids will not be accepted. Douglas County is not responsible for the lost or misdirected bids, whether lost or misdirected by the postal or courier service of the bidder or the Douglas County mail room.

The awarded bidder shall agree to offer the prices and the terms and conditions herein to other government agencies who wish to participate in a cooperative purchase program with Douglas County. Other agencies will be responsible for entering into separate agreements with the awarded bidder and for all payments thereunder.

The Douglas County Department of Public Works reserves the right to reject any or all bids, or portions of bids, waive technicalities, and to purchase the items, which in the opinion of the Board, are best suited for the use intended.

Dated: March 10, 2014

DEPARTMENT OF PUBLIC WORKS  
DOUGLAS COUNTY, KANSAS  
Keith A. Browning, P.E.  
Director of Public Works

Published: Thursday, March 13, 2014  
Sunday, March 16, 2014

cc: Lawrence Journal World  
Board of County Commissioners  
County Clerk  
County Administrator  
County Shop  
Public Works Accounting  
Purchasing Department  
File

DOUGLAS COUNTY PUBLIC WORKS DEPARTMENT

Bid No. 14-F-0002  
**Signs and Accessories**  
FY 2014

**Instructions to Bidders**

1. It is the intent of Douglas County to purchase the various Signs and Accessories listed in this brochure.
2. Proposals must be submitted on forms provided by either the Douglas County Public Works Department, 1242 Massachusetts Street, Lawrence, Kansas or Demand Star @ www.demandstar.com. Specifications and bid requirements are included in these documents. The proposal must be left intact and will be the only form accepted as a bid by the Board of County Commissioners.
3. Bidders shall show unit prices for each item listed, shall extend all unit prices and total all extensions. All prices shall be F.O.B. Lawrence, Kansas. The County is not subject to City or State Sales Tax.
4. The Devices specified shall conform to the Manual on Uniform Traffic Control Devices, latest edition, as approved by the Federal Highway Administrator as part of the National Standard for all Highways, unless otherwise indicated in the specifications.
5. Bidders shall specify delivery date. Delivery date will be considered, as well as total price, in the selection of the successful bidder. Liquidated damages in the amount of 1% per day of the total bid price of items not received by the specified delivery date will be charged.
6. **The supplier must notify Douglas County 48 hours prior to delivery.** Douglas County reserves the right to refuse any shipment if proper advance notice is not received.
7. The back face of all finished signs shall be permanently marked with the producers name and year of manufacture. The size of the identification shall be no larger than 4" X 2", unless previously approved by the County Engineer.
8. The awarded bidder shall agree to offer the prices and the terms and conditions offered herein to other governmental agencies who wish to participate in a cooperative purchase program with Douglas County. All other agencies contracting with any vendor shall be responsible for entering into separate agreements and for all payments thereunder.
9. Bids must be sealed and received in the Douglas County Clerk's Office, Douglas County Courthouse, 1100 Massachusetts, Lawrence, Kansas 66044, prior to 3:15 P.M., Tuesday, April 1, 2014. Faxed bids will not be accepted. The County is not responsible for lost or misdirected bids, whether lost or misdirected by the postal or courier service of the bidder or the County mail room. Any bids received after the time specified will be returned unopened.
10. The County reserves the right to reject any or all bids or waive technicalities and to purchase the items which, in the opinion of the Board of County Commissioners, are best suited to the work for which they are intended. **The award will be made to the lowest and best bidder for each group of items specified (finished signs, fluorescent signs, cut out lettering, steel posts and telespar posts). Miscellaneous items will be awarded on an item by item basis.**

### Instructions to Bidders (continued)

11. All sheeting used on sign faces shall be TYPE IV High Intensity Prismatic Grade or TYPE VIII or better for Fluorescent Orange, Yellow and Yellow/Green sheeting meeting the requirements stated in Section 2201, "Retroreflective Sheeting", of the KDOT Standard Specifications, 2007 Edition, unless otherwise indicated in the bid documents. A copy of this specification is attached to this proposal, or may be viewed at <http://www.ksdot.org/burconsmain/specprov/2007/2201.pdf>. A list of pre-qualified materials can be found at <http://www.ksdot.org/burmatres/pql/default.asp>.
12. The chip and seal markers shall meet the requirements stated in Special Provision 07-22004 (Temporary Raised Pavement Markers) in Section 2200, "Reflective Materials and Accessory Items", of the KDOT Standard Specifications, 2007 Edition. A copy of this Special Provision is attached to this proposal, or may be viewed at <http://www.ksdot.org/burconsmain/specprov/2007/pdf/07-22004.pdf>.
13. All sign blanks shall be a minimum of .080 gauge aluminum (except those greater than 36" in any dimension, which shall be .10 gauge), unless otherwise specified.

STANDARD TERMS AND CONDITIONS  
DOUGLAS COUNTY, KANSAS

1. SCOPE: The following terms and conditions shall prevail unless otherwise modified by Douglas County within this bid document. Douglas County reserves the right to accept or reject any or all bids received, waive technicalities, and to purchase the products, which in the opinion of the Board of County Commissioners, is best suited to the work for which it is intended.
2. DEFINITIONS AS USED HEREIN:
  - a. The term "bid request" means a solicitation of a formal sealed bid.
  - b. The term "bid" means the price offered by the bidder.
  - c. The term "bidder" means the offer or vendor.
  - d. The term "County" means Douglas County, Kansas.
  - e. The term "Board of County Commissioners or "BOCC" means the governing body of Douglas County, Kansas.
  - f. The term "awarded bidder" means any bidder awarded a contract pursuant to its bid.
3. COMPLETING BID: Bids must be submitted only on the forms (or reproductions thereof) provided in this document. All information must be legible. Any and all corrections and/or erasures must be initialed. Each bid sheet must be signed by the authorized bidder and all required information must be provided.
4. CONFIDENTIALITY OF BID INFORMATION: Each bid must be sealed and submitted in an envelope clearly marked "SIGNS AND ACCESSORIES" to provide confidentiality of the bid information prior to the bid opening. Supporting documents and/or descriptive literature may be submitted with the bid. Do not indicate bid prices on literature.

All bids and supporting bid documents become public information after the bid opening and are available for public inspection by the general public in accordance with the Kansas Open Records Act.
5. ACCURACY OF BID: Each bid is publicly opened in the presence of the Douglas County Clerk. It is required that any and all information presented is accurate and/or will be that by which the bidder will perform if awarded the contract. If there is a discrepancy between the unit price and extended total, the unit price will prevail.
6. SUBMISSION OF BID: Bids must be sealed and received in the Douglas County Clerk's Office, Douglas County Courthouse, 1100 Massachusetts, Lawrence, Kansas 66044, prior to 3:15 P.M., Tuesday, April 1, 2014. Faxed bids will not be accepted. The County is not responsible for lost or misdirected bids, whether lost or misdirected by the postal or courier service of the bidder or the County mail room.
7. ADDENDA: All changes in connection with this bid will be issued in the form of a written addendum. Signed acknowledgment of receipt of each addendum must be submitted with the bid.



STANDARD TERMS AND CONDITIONS (continued)

8. LATE BIDS, CHANGES OR WITHDRAWALS: Bids received after the deadline designated in this bid document shall not be considered and shall be returned unopened.

Bids may be changed or withdrawn prior to the bid opening. All such transactions must be submitted in writing and received by the County Clerk's Office prior to the bid deadline. Changes or withdrawals may be made after the bid deadline only with the approval of the Board of County Commissioners. After bid opening, no changes in bid prices or other provisions of bids prejudicial to the interest of the County or fair competition shall be permitted.

9. BIDS BINDING: All bids submitted shall be binding upon the bidder if accepted by the County within fifteen (15) calendar days after the bid opening.
10. EQUIVALENT BIDS: When brand or trade names are used in the bid invitation, it is for the purpose of item identification and to establish standards for quality, style and features. Bids on equivalent items of substantially the same quality, style and features are invited unless items are marked "No Substitute." Equivalent bids must be accompanied by descriptive literature and/or specifications to receive consideration. Demonstrations and/or samples may be required and shall be supplied at no charge to the County.
11. NEW MATERIALS, SUPPLIES OR EQUIPMENT: Unless otherwise specified, all materials, supplies or equipment offered by a bidder shall be new, unused, of recent manufacture, first class in every respect and suitable for their intended purpose. All equipment shall be assembled, and ready for operation when delivered.
12. WARRANTY: Supplies or services furnished as a result of this bid shall be covered by the most favorable commercial warranties, expressed or implied, that the bidder and/or manufacturer gives to any customer. The rights and remedies provided herein are in addition to and do not limit any rights afforded to the County by any other clause of this bid. The County reserves the right to request from bidders a separate manufacturer certification of all statements made in the proposal.
13. METHOD OF AWARD AND NOTIFICATION: Bids will be evaluated and the award made to the lowest and best, responsive and responsible bidder(s) whose bid conforms to the specifications and whose bid is considered to be the best value in the opinion of the Board of County Commissioners.

The County reserves the right to accept or reject any or all bids and any part of a bid and to waive informalities, technical defects, and minor irregularities in bids received. **The award will be made to the lowest and best bidder for each group of items specified (finished signs, fluorescent signs, cut out lettering, steel posts and telespar posts). Miscellaneous items will be awarded on an item by item basis.**

The signed bid shall be considered an offer on the part of the bidder; such offer shall be deemed accepted upon issuance by the County of a Purchase Order or other contractual document.

STANDARD TERMS AND CONDITIONS (continued)

14. DELIVERY TERMS: All deliveries shall be F.O.B. Lawrence, Kansas and all freight charges shall be included in the bid price. Delivery date shall be considered as a cost factor in the determination of award.
15. DAMAGED AND/OR LATE SHIPMENTS: The County has no obligation to accept damaged shipments and reserves the right to return at the vendor's expense damaged merchandise even though the damage was not apparent or discovered until after receipt of the items. The Vendor is responsible to notify the Douglas County Department of Public Works of any late or delayed shipments. The County reserves the right to cancel all or any part of an order if the shipment is not made as promised.
16. CREDIT TERMS: Bidder shall indicate all discounts for full and/or prompt payment. Discounts offered shall be computed from date of receipt of correct invoice or receipt and acceptance of products, whichever is later.
17. SELLERS INVOICE: Invoices shall be prepared and submitted in at least two copies to the address shown on the Purchase Order or bid document. Separate invoices are required for each Purchase Order or bid document. Invoices shall contain the following information: Purchase order number and date, bid number, item number, description of supplies or services, sizes, unit of measure, quantity, unit price and extended totals.
18. TAX EXEMPT: The County and its agencies are exempt from State and local sales taxes by K.S.A. 79-3606, as amended. Situs of all transactions under the order(s) that shall be derived from this request shall be deemed to have been accomplished within the State of Kansas.
19. SAFETY: All practices, materials, supplies and equipment shall comply with the Federal Occupational Safety and Health Act, as well as any pertinent Federal, state and/or local safety or environmental codes.
20. DISCLAIMER OF LIABILITY: The County, or any of its agencies, will not hold harmless or indemnify any bidder for any liability whatsoever.
21. HOLD HARMLESS: The awarded bidder agrees to protect, defend, indemnify and hold the Board of County Commissioners, its officers, employees and agents free and harmless from and against any and all losses, penalties, damages, settlements, costs, charges, professional fees or other expenses or liabilities of every kind and character arising out of or relating to any and all claims, liens, demands, obligations, actions, proceedings or causes of action of every kind and character in connection with or arising directly or indirectly out of this agreement and/or the performance hereof. Without limiting the generality of the foregoing, and all such claims, etc., relating to personal injury, infringement of any patent, trademark, copyright (or application for any thereof) or of any other tangible or intangible personal or property right, or actual or alleged violation of any applicable statute, ordinance, administrative order, rule or regulation, or decree of any court, shall be included in the indemnity hereunder. The awarded bidder further agrees to investigate, handle, respond to, provide defense for and defend any such claims, etc., at his/her sole expense and agrees to bear all other costs and expenses related thereto, even if such claim is groundless, false or fraudulent.

STANDARD TERMS AND CONDITIONS (continued)

22. LAW GOVERNING: All contractual agreements shall be subject to, governed by, and construed according to the laws of the State of Kansas.
23. ANTI-DISCRIMINATION CLAUSE: No bidder on this request shall in any way, directly or indirectly, discriminate against any person because of age, race, color, handicap, sex, national origin, or religious creed.

BID  
For  
VARIOUS SIGNS AND ACCESSORIES

**Bid No. 14-F-0002**

Price shall include delivery to the Douglas County Shop, 23rd and Santa Fe Tracks, 711 E 23<sup>rd</sup> St., Lawrence, Kansas.

The Devices specified shall conform to the Manual on Uniform Traffic Control Devices, latest edition, as approved by the Federal Highway Administrator as part of the National Standard for all Highways unless otherwise indicated in the Specifications and Contract Documents.

The Douglas County Public Works 2014 Combined Sign Bid attached hereto is incorporated herein by this reference and is the undersigned bidders bid.

Bids must be returned to the Office of the Douglas County Clerk no later than, 3:15 P.M., Tuesday, April 1, 2014.

**The bidder shall notify Douglas County 48 hours prior to delivery.**

Date available for delivery: 30 days ARO

Bidder: Osburn Associates, Inc.

By: Steven C. Gaughan

Recommended for Approval:

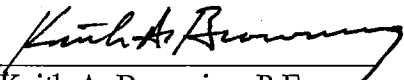
  
Keith A. Browning, P.E.  
Director of Public Works

DOUGLAS COUNTY, KANSAS  
Board of County Commissioners

\_\_\_\_\_  
Nancy Thellman, Chairman

\_\_\_\_\_  
Mike Gaughan, Member

\_\_\_\_\_  
Jim Flory, Member

\_\_\_\_\_  
Date

SECTION 2201

RETROREFLECTIVE SHEETING

2201.1 DESCRIPTION

This specification covers Type I and all Types of High Intensity retroreflective sheeting. This includes both non-exposed glass bead lens and micropismatic sheeting.

2201.2 REQUIREMENTS

a. **General.** Provide retroreflective sheeting that complies with ASTM D 4956 (latest revision) except for the color limits as specified in subsection 2201.2b. The type to be provided will be shown in the Contract Documents. Types and classes are as defined in ASTM D 4956.

b. **Color.** The colors of the retroreflective sheeting are white, yellow, red, orange, green, blue, brown, fluorescent orange, fluorescent yellow, and fluorescent yellow-green. Provide colors that comply with the chromaticity limits as shown in TABLE 2201-1 for both Type I and Type III sheeting and TABLE 2201-2 for all other Types of High Intensity sheeting (Type IV through Type XI). Provide fluorescent colors that comply with the chromaticity limits in ASTM D 4956 (latest revision).

TABLE 2201-1: COLOR SPECIFICATION (Type I and Type III)								
COLOR	Chromaticity Coordinates							
	1		2		3		4	
	x	y	x	y	x	y	x	y
White	0.310	0.313	0.338	0.342	0.325	0.355	0.300	0.327
Yellow	0.496	0.503	0.545	0.454	0.505	0.433	0.460	0.474
Red	0.574	0.337	0.665	0.345	0.708	0.292	0.613	0.297
Orange	0.558	0.352	0.636	0.364	0.570	0.429	0.506	0.404
Green	0.130	0.387	0.180	0.410	0.140	0.521	0.098	0.490
Blue	0.138	0.065	0.112	0.135	0.160	0.170	0.176	0.120
Brown	0.430	0.340	0.610	0.390	0.550	0.450	0.430	0.390

TABLE 2201-2: COLOR SPECIFICATION (Type IV - Type XI)								
COLOR	Chromaticity Coordinates							
	1		2		3		4	
	x	y	x	y	x	y	x	y
White	0.310	0.313	0.328	0.331	0.316	0.345	0.300	0.327
Yellow	0.515	0.484	0.545	0.454	0.505	0.433	0.475	0.460
Red	0.586	0.324	0.664	0.336	0.708	0.292	0.613	0.297
Orange	0.558	0.352	0.636	0.364	0.570	0.429	0.506	0.404
Green	0.130	0.387	0.180	0.410	0.155	0.478	0.107	0.457
Blue	0.138	0.065	0.112	0.135	0.160	0.170	0.176	0.120
Brown	0.430	0.340	0.610	0.390	0.550	0.450	0.430	0.390

c. **Conformable Retroreflective Sheeting.** Provide High Intensity retroreflective sheeting that has a conformable aluminum foil backing with an aggressive pressure sensitive adhesive. This material is designed for application to moderately rough or porous metal, wood or masonry surfaces. Provide material that complies with ASTM D 4956 (latest revision) with the following exceptions and additions:

- (1) Conformable aluminum backing thickness - 0.005 inches to 0.010 inches.
- (2) Follow all manufacturers' recommendations for application procedures and temperatures.

2201.3 MANUFACTURER WARRANTY

The following warranty conditions apply only to the retroreflective sheeting manufacturer. Provide a product warranty for a minimum period of 10 years on all Types of High Intensity retroreflective sheeting, for placement on permanent signing. Failure to comply with this warranty may be cause for removal from the prequalified list.

The High Intensity retroreflective sheeting warranty must comply with the following requirements and obligations:

- Certification: Submit with each lot or shipment, a certification which states that the material supplied is subject to and complies with the requirements. Include in the certification, the manufacturer's office, address, phone number and the contact for potential claims under the provisions of this warranty. Provide documentation as to which signs were fabricated from each lot.
- Field Performance: Field Performance applies to retroreflective sheeting applied to sign blank materials or overlaid on existing signs. The field performance obligation period begins with the date of erection. The sheeting is considered unsatisfactory if it has deteriorated due to natural causes to the extent that the sign is ineffective for its intended purpose when viewed from a moving vehicle under normal day and night driving conditions or shows any of the following defects:
  - Cracking discernible with the unaided eye from a driver's position at a distance of 50 feet or greater from the sign;
  - More than 25% loss of specular gloss and cracking, scaling, pitting, orange peel, delamination, edge lifting or curling;
  - Peeling in excess of 3/8 inch;
  - Shrinkage in excess of 3/16 inch total per yard of sheeting width;
  - Fading or loss of color to the extent that retroreflective sheeting color fails to comply with the subsection 2201.2b., or;
  - Loss of retroreflectivity reducing the coefficient of retroreflection as measured by a retroreflectometer to less than the minimum specified in TABLE 2201-3 at 0.2° observation and -4° entrance angles. Make all measurements after cleaning the sign.

Sheeting Color	Min. Coefficient
White	200
Yellow	136
Green	36
Red	36
Blue	16
Brown	9

**Defective Material Replacement:** When traffic signs with High Intensity sheeting fail to comply with the field performance requirements, re-sheet or replace the signs at no cost to the Douglas County for materials and labor. Employ a contractor qualified by the KDOT to perform signing work. Install highway signs, as shown in the Contract Documents and the M.U.T.C.D. (latest edition) and provide proper traffic control.

Replace all defective material within 60 days after written notification by Douglas County. Signs not corrected within 60 days, will be removed and replaced by Douglas County. Signs removed by Douglas County will be placed in storage for inspections by the manufacturer, and the manufacturer will be billed for all costs of replacement of the sheeting.

When more than 25% of the signs within a lot fail to comply with the requirements, replace all signs made from that lot.

#### **2201.4 PREQUALIFICATION**

Manufacturers desiring to provide material under this specification are to submit prequalification samples of each type, class and color covered by this specification which they wish to prequalify. Each sample consists of 3 pieces 24 inches square.

Forward the prequalification samples to the Engineer of Tests, Materials and Research Center, 2300 Van Buren, Topeka, KS 66611. Samples will be tested for compliance with all requirements of this specification. Each Manufacturer will be notified of the test results.

If the prequalification samples of retroreflective sheeting comply with this specification, the product will be placed on a list of prequalified products maintained by the Bureau of Materials and Research. No retroreflective sheeting will be used on KDOT projects unless it has been prequalified. Manufacturers will be required to requalify at intervals determined by the Engineer of Tests.

Testing and evaluation by KDOT may be waived if complete testing has been performed on the identical product by AASHTO National Transportation Product Evaluation Program (NTPEP). Forward an official copy of the test report along with evidence that the product referenced is identical to that submitted for prequalification, to the Engineer of Tests for evaluation.

## **2201.5 METHODS OF TESTS**

All tests will be conducted in accordance with ASTM D 4956 with the exception of artificial weathering. Artificial weathering will be conducted according to ASTM G 155, Cycle 1, with the following additions and exceptions:

- At the end of each 20 hour cycle, the panels will be placed in a cold cabinet at approximately 0°F for one hour. After removal from the cold cabinet, panels will be returned to the weatherometer to await the start of the next cycle.
- Water used in the weatherometer will be city water softened to a total hardness content of less than 5 parts per million expressed as calcium carbonate.

## **2201.6 BASIS OF ACCEPTANCE**

### **a. Permanent Sheeting.**

- (1) Prequalification as required by subsection 2201.4.
- (2) Satisfactory results of tests conducted at MRC. Each lot of sheeting will be sampled at destination by a representative of the KDOT and will be subjected to a visual examination and tested for physical properties as necessary to verify that the sheeting complies with this specification.
- (3) Receipt of the warranty certification as specified in subsection 2201.3 by the County Engineer.

**b. Temporary Sheeting.** Retroreflective sheeting used to manufacture temporary traffic control signs will be accepted on the basis of a certification prepared by the contractor stating that the retroreflective sheeting used to manufacture the signs was prequalified under this specification, and visual inspection by the Engineer for condition and other requirements.

**KANSAS DEPARTMENT OF TRANSPORTATION  
SPECIAL PROVISION TO THE  
STANDARD SPECIFICATIONS, EDITION 2007**

Add a new SECTION in DIVISION 2200:

**TEMPORARY RAISED PAVEMENT MARKERS**

**1.0 DESCRIPTION**

This specification covers temporary raised pavement markers for lane marking and delineation. This includes both Flexible and Rigid (Types I and II) markers for use on both Portland cement concrete and asphalt surfaces.

**2.0 REQUIREMENTS**

**a. General.**

(1) Provide temporary reflective markers as shown in the Contract Documents. The markers shall be readily visible at night, from a minimum of 300 feet, when viewed with high beam automobile headlamps. Prior to use, markers must be approved by the Engineer. The marker shall be the same color as the reflective elements. All markers shall be capable of sustaining 2000 direct wheel-over impacts at 60 mph without losing adhesion to the roadway or sustaining damage to the marker body.

(2) Provide Flexible temporary raised pavement markers which consist of an L-shaped flexible polyurethane body with prismatic reflective sheeting on both faces. The reflective sheeting shall be a minimum of 1 square inch spread over the 4" wide marker. The markers shall have minimum dimensions of 4 inches wide x 2 inches high with a 1 inch wide base leg. Thickness of the body shall be a minimum of 0.06 inches. The marker shall have an affixed pressure sensitive adhesive, protected by a release paper, for application to the pavement surface. Attach a clear flexible plastic cover to the vertical section of the marker to protect the reflective material during surfacing operations. The cover shall withstand the work and be easily removed after the operation. The markers shall not cause any damage to the automobile.

(3) Provide Rigid (Type I) temporary raised pavement markers constructed of traffic bearing high impact plastic with prismatic reflective faces. The base of the markers shall have minimum dimensions of 2.5 inches wide, 4 inches long and 0.4 inches high. The base of the marker shall be flat. Markers shall be reflectorized with one or more reflective faces on each side using either an acrylic retroreflector, or retroreflective sheeting. Each face shall contain a minimum of 0.38 square inches of reflective surface. The adhesive used shall not stain the pavement and will allow the markers to be easily removed without damage to the roadway surface. If the marker is self adhesive, it shall be pre-coated with an affixed pressure sensitive adhesive, protected by a release paper.

(4) Provide Rigid (Type II) or brick markers constructed of traffic bearing high impact plastic with prismatic reflective faces. The marker shall have minimum dimensions of 2.5 inches high, 7.5 inches wide and 13 inches long. The base of the marker shall be flat. Markers shall be reflectorized with two or more reflective faces on each side using either an acrylic retroreflector, or retroreflective sheeting. Each face shall contain a minimum of 3.75 square inches of reflective surface. The adhesive used will allow the markers to be removed without damage to the roadway surface. If the marker is self adhesive, it shall be pre-coated with an affixed pressure sensitive adhesive, protected by a release paper.

**b. Retroreflectivity.** Provide markers in white or yellow which comply with the minimum requirements shown in TABLE 1:

<b>TABLE 1: RETROREFLECTIVITY REQUIREMENTS</b>	
<b>Color</b>	<b>Millicandelas/sq m/lux (min.)<sup>a</sup> (measured at 0.2° observation angle and 0° entrance angle)</b>
White	3.0
Yellow	1.8

<sup>a</sup> Flexible markers must meet these requirements before and after durability testing



c. **Color.** Markers shall be white or yellow in color, solid throughout, and match the color of the lane line on which the marker will be placed under both daylight and nighttime conditions.

d. **Durability.** Flexible markers, as defined in subsection 2.0a.(2), must withstand 2000 revolutions on a small-wheel circular track. 12 markers of each color will be tested. No more than 3 markers shall move from their original position during testing.

### 3.0 TEST METHODS

a. **Retroreflectivity.** Test in accordance with ASTM E 809.

b. **Durability.** Test in accordance with ASTM E 660, with the following variations:

(1) Mount two opposite wheels with 11 x 6.00 x 5 nylon smooth non-pattern tread tires with a total load of 50 pounds on each tire. Maintain tire pressure at 25 psi. Mount the wheels perpendicular to the specimens and toe out 2° to produce a slight abrading action.

(2) Apply markers, according to the manufacturer's recommendations, to 6 inch diameter dense grade asphalt concrete cores, which have been compacted at 3000 psi for 2 minutes.

### 4.0 PREQUALIFICATION

Manufacturers wishing to supply markers to KDOT projects must have their product tested by the AASHTO National Transportation Product Evaluation Program (NTPEP). Submit 12 flexible markers or 2 rigid markers of each color for which prequalification is requested, and an official copy of the NTPEP test report to the Engineer of Tests, Materials and Research Center, 2300 Van Buren, Topeka, KS 66611. Include evidence that the product offered is identical to that described in the test report, and information regarding the recommended adhesive, if any is required. Prequalification will be based on satisfactory compliance of NTPEP results and laboratory testing with subsection 2.0.

### 5.0 BASIS OF ACCEPTANCE

Prequalification as required by subsection 4.0.

Receipt and approval of a Type C certification as specified in DIVISION 2600.

Visual inspection for condition and dimensional requirements.

09-06-12 M&R (SML/KJS)  
Jan-13 Letting

DOUGLAS COUNTY PUBLIC WORKS  
2014 COMBINED SIGN BID

*Handwritten initials/signature*

3/5/2014

FINISHED SIGNS

MUTCD #	SIZE	DESCRIPTION	COLOR	SHEETING	REMARKS	# TO ORDER	UNIT COST	EXTENDED COST
M1-6	24 X 24	DOUGLAS COUNTY	YELLOW/BLUE	TY IV, H/I PRISM.	NO ROUTE NUMBER	10	\$ 17.44	\$ 174.40
M1-6	24 X 24	DOUGLAS COUNTY 1	YELLOW/BLUE	TY IV, H/I PRISM.	ROUTE MARKER	4	\$ 17.44	\$ 69.76
M1-6	24 X 24	DOUGLAS COUNTY 1S	YELLOW/BLUE	TY IV, H/I PRISM.	ROUTE MARKER	5	\$ 17.44	\$ 87.20
M1-6	24 X 24	DOUGLAS COUNTY 1W	YELLOW/BLUE	TY IV, H/I PRISM.	ROUTE MARKER	5	\$ 17.44	\$ 87.20
M1-6	24 X 24	DOUGLAS COUNTY 1E	YELLOW/BLUE	TY IV, H/I PRISM.	ROUTE MARKER	5	\$ 17.44	\$ 87.20
M1-6	24 X 24	DOUGLAS COUNTY 2	YELLOW/BLUE	TY IV, H/I PRISM.	ROUTE MARKER	5	\$ 17.44	\$ 87.20
M1-6	24 X 24	DOUGLAS COUNTY 3	YELLOW/BLUE	TY IV, H/I PRISM.	ROUTE MARKER	5	\$ 17.44	\$ 87.20
M1-6	24 X 24	DOUGLAS COUNTY 4	YELLOW/BLUE	TY IV, H/I PRISM.	ROUTE MARKER	4	\$ 17.44	\$ 69.76
M1-6	24 X 24	DOUGLAS COUNTY 6	YELLOW/BLUE	TY IV, H/I PRISM.	ROUTE MARKER	10	\$ 17.44	\$ 174.40
M1-6	24 X 24	DOUGLAS COUNTY 438	YELLOW/BLUE	TY IV, H/I PRISM.	ROUTE MARKER	7	\$ 17.44	\$ 122.08
M1-6	24 X 24	DOUGLAS COUNTY 442	YELLOW/BLUE	TY IV, H/I PRISM.	ROUTE MARKER	5	\$ 17.44	\$ 87.20
M1-6	24 X 24	DOUGLAS COUNTY 460	YELLOW/BLUE	TY IV, H/I PRISM.	ROUTE MARKER	10	\$ 17.44	\$ 174.40
M1-6	24 X 24	DOUGLAS COUNTY 1023	YELLOW/BLUE	TY IV, H/I PRISM.	ROUTE MARKER	10	\$ 17.44	\$ 174.40
M1-6	24 X 24	DOUGLAS COUNTY 1029	YELLOW/BLUE	TY IV, H/I PRISM.	ROUTE MARKER	10	\$ 17.44	\$ 174.40
M1-6	24 X 24	DOUGLAS COUNTY 1039	YELLOW/BLUE	TY IV, H/I PRISM.	ROUTE MARKER	7	\$ 17.44	\$ 122.08
M4-6	24 X 12	"END" - AUXILIARY SIGN	BLACK/WHITE	TY IV, H/I PRISM.		5	\$ 8.22	\$ 41.10
M6-1	21 X 15	DIRECTIONAL SIGN	BLACK/WHITE	TY IV, H/I PRISM.		10	\$ 8.99	\$ 89.90
OM2-2V	6 X 12	TYPE 2 OBJECT MARKER	YELLOW	TY IV, H/I PRISM.		400	\$ 1.75	\$ 700.00
OM2-2V	6 X 12	TYPE 2 OBJECT MARKER	WHITE	TY IV, H/I PRISM.		50	\$ 1.95	\$ 97.50
OM3-L	12 X 36	OBJECT MARKER TYPE III - LEFT	BLACK/YELLOW	TY IV, H/I PRISM.	SEE PLAN DETAILS	254	\$ 11.64	\$ 2956.56
OM3-R	12 X 36	OBJECT MARKER TYPE III - RIGHT	BLACK/YELLOW	TY IV, H/I PRISM.	SEE PLAN DETAILS	250	\$ 11.64	\$ 2910.00
OM4-3	18 X 18	END OF ROAD MARKER	RED	TY IV, H/I PRISM.		24	\$ 8.75	\$ 210.00
R1-1	30 X 30	STOP SIGN	WHITE/RED	TY IV, H/I PRISM.		20	\$ 23.50	\$ 470.00
R1-2	30 X 30 X 30	YIELD	WHITE/RED	TY IV, H/I PRISM.		1	\$ 12.84	\$ 12.84
R1-3P	18 X 6	ALL WAY	WHITE/RED	TY IV, H/I PRISM.		8	\$ 3.08	\$ 24.64
R2-1	24 X 30	"SPEED LIMIT"	BLACK/WHITE	TY IV, H/I PRISM.	NO SPEED LIMIT NUMBER	7	\$ 19.95	\$ 139.65
R2-1-25	24 X 30	"SPEED LIMIT 25"	BLACK/WHITE	TY IV, H/I PRISM.		4	\$ 19.95	\$ 79.80
R2-1-40	24 X 30	"SPEED LIMIT 40"	BLACK/WHITE	TY IV, H/I PRISM.		5	\$ 19.95	\$ 99.75
R2-1-55	24 X 30	"SPEED LIMIT 55"	BLACK/WHITE	TY IV, H/I PRISM.		20	\$ 19.95	\$ 399.00
R5-1	30 X 30	"DO NOT ENTER"	WHITE/RED	TY IV, H/I PRISM.		2	\$ 25.00	\$ 51.20
R7-1	12 X 18	NO PARKING <—>	WHITE/RED	TY IV, H/I PRISM.	DOUBLE ARROW BELOW "NO PARKING"	5	\$ 6.15	\$ 30.75
R7-1	18 X 24	NO PARKING <—>	WHITE/RED	TY IV, H/I PRISM.	DOUBLE ARROW BELOW "NO PARKING"	4	\$ 12.30	\$ 49.20
R7-1L	12 X 18	NO PARKING <—	WHITE/RED	TY IV, H/I PRISM.	LEFT ARROW BELOW "NO PARKING"	4	\$ 6.15	\$ 24.60
R7-1L	18 X 24	NO PARKING <—	WHITE/RED	TY IV, H/I PRISM.	LEFT ARROW BELOW "NO PARKING"	7	\$ 12.30	\$ 86.10
R7-1R	12 X 18	NO PARKING —>	WHITE/RED	TY IV, H/I PRISM.	RIGHT ARROW BELOW "NO PARKING"	5	\$ 6.15	\$ 30.75
R7-1R	18 X 24	NO PARKING —>	WHITE/RED	TY IV, H/I PRISM.	RIGHT ARROW BELOW "NO PARKING"	2	\$ 12.30	\$ 24.60
R11-2	48 X 30	"ROAD CLOSED"	BLACK/WHITE	TY IV, H/I PRISM.	2 LINES	7	\$ 47.00	\$ 329.00
R11-3a	60 X 30	"ROAD CLOSED ___ MILES AHEAD LOCAL TRAFFIC ONLY"	BLACK/WHITE	TY IV, H/I PRISM.	3 LINES	45	\$ 20.50	\$ 922.50
R12-1	24 X 30	"WEIGHT LIMIT ___ TONS"	BLACK/WHITE	TY IV, H/I PRISM.		5	\$ 20.50	\$ 102.50
R12-5	24 X 36	"WEIGHT LIMIT ___ TONS"	BLACK/WHITE	TY IV, H/I PRISM.	3 TIER W/ NO DISPLAYED # - "T" ONLY	10	\$ 24.66	\$ 246.60

SUBTOTAL FINISHED SIGNS

\$ 11,294.12 ✓

Bid Submitted By: Coburn Associates, Inc.  
Authorized Signature: [Signature]

DOUGLAS COUNTY PUBLIC WORKS  
2014 COMBINED SIGN BID

3/5/2014

FINISHED SIGNS (CONTINUED)

MUTCD #	SIZE	DESCRIPTION	COLOR	SHEETING	REMARKS	# TO ORDER	UNIT COST	EXTENDED COST
W1-1L	30 X 30	LEFT TURN ARROW	BLACK/YELLOW	TY IV, H/I PRISM.		4	\$ 25.60	\$ 102.40-
W1-1L	48 X 48	LEFT TURN ARROW	BLACK/YELLOW	TY IV, H/I PRISM.		2	\$ 65.75	\$ 148.16-
W1-1R	36 X 36	RIGHT TURN ARROW	BLACK/YELLOW	TY IV, H/I PRISM.		4	\$ 36.90	\$ 147.60-
W1-1R	48 X 48	RIGHT TURN ARROW	BLACK/YELLOW	TY IV, H/I PRISM.		3	\$ 65.75	\$ 222.24-
W1-2L	30 X 30	CURVE SIGN - LEFT	BLACK/YELLOW	TY IV, H/I PRISM.		2	\$ 25.60	\$ 51.20-
W1-2L	36 X 36	CURVE SIGN - LEFT	BLACK/YELLOW	TY IV, H/I PRISM.		3	\$ 36.90	\$ 110.70-
W1-2L	48 X 48	CURVE SIGN - LEFT	BLACK/YELLOW	TY IV, H/I PRISM.		2	\$ 65.75	\$ 148.16-
W1-2R	30 X 30	CURVE SIGN - RIGHT	BLACK/YELLOW	TY IV, H/I PRISM.		5	\$ 25.60	\$ 128.00-
W1-2R	36 X 36	CURVE SIGN - RIGHT	BLACK/YELLOW	TY IV, H/I PRISM.		4	\$ 36.90	\$ 147.60-
W1-3R	30 X 30	REVERSE TURN SIGN - RIGHT	BLACK/YELLOW	TY IV, H/I PRISM.		1	\$ 25.60	\$ 25.60-
W1-6	36 X 18	ONE-DIRECTION LARGE ARROW	BLACK/YELLOW	TY IV, H/I PRISM.		4	\$ 18.50	\$ 74.00-
W1-6	48 X 24	ONE-DIRECTION LARGE ARROW	BLACK/YELLOW	TY IV, H/I PRISM.		3	\$ 38.88	\$ 116.64-
W1-7	36 X 18	TWO-DIRECTION LARGE ARROW	BLACK/YELLOW	TY IV, H/I PRISM.		3	\$ 18.50	\$ 55.50-
W1-7	48 X 24	TWO-DIRECTION LARGE ARROW	BLACK/YELLOW	TY IV, H/I PRISM.		5	\$ 38.88	\$ 194.40-
W1-8	18 X 24	CHEVRON ALIGNMENT SIGN	BLACK/YELLOW	TY IV, H/I PRISM.		60	\$ 11.97	\$ 718.20-
W2-4	30 X 30	T-INTERSECTION AHEAD	BLACK/YELLOW	TY IV, H/I PRISM.		3	\$ 25.60	\$ 76.80-
W3-5	36 X 36	REDUCE SPEED LIMIT AHEAD 30	BL-WHITE/YELLOW	TY IV, H/I PRISM.		4	\$ 41.90	\$ 167.60-
W3-5	36 X 36	REDUCE SPEED LIMIT AHEAD 40	BL-WHITE/YELLOW	TY IV, H/I PRISM.		5	\$ 41.90	\$ 209.50-
W8-6	30 X 30	TRUCK CROSSING	BLACK/YELLOW	TY IV, H/I PRISM.		4	\$ 25.60	\$ 102.40-
W8-17	30 X 30	SHOULDER DROP OFF (SYMBOL)	BLACK/YELLOW	TY IV, H/I PRISM.		7	\$ 25.60	\$ 179.20-
W10-1	36" DIA	GRADE CROSSING ADVANCE WARNING	BLACK/YELLOW	TY IV, H/I PRISM.	(RAILROAD EMBLEM)	6	\$ 36.90	\$ 221.40-
W11-8	36 X 36	EMERGENCY VEHICLE	BLACK/YELLOW	TY IV, H/I PRISM.		5	\$ 36.90	\$ 184.50-
W11-8P	24 X 18	"FIRE STATION"	BLACK/YELLOW	TY IV, H/I PRISM.	TWO LINES	4	\$ 12.33	\$ 49.32-
W13-1P	18 X 18	"20 MPH"	BLACK/YELLOW	TY IV, H/I PRISM.		5	\$ 9.25	\$ 46.25-
W13-1P	18 X 18	"35 MPH"	BLACK/YELLOW	TY IV, H/I PRISM.		5	\$ 9.25	\$ 46.25-
W13-1P	24 X 24	"45 MPH"	BLACK/YELLOW	TY IV, H/I PRISM.		6	\$ 16.44	\$ 98.64-
W14-1	30 X 30	"DEAD END"	BLACK/YELLOW	TY IV, H/I PRISM.		5	\$ 25.60	\$ 128.00-
W14-2	30 X 30	"NO OUTLET"	BLACK/YELLOW	TY IV, H/I PRISM.	DIAMOND SHAPE	6	\$ 25.60	\$ 153.60-
W14-3	48 X 48 X 36	"NO PASSING ZONE" PENNANT	BLACK/YELLOW	TY IV, H/I PRISM.	2 HOLES FOR 1 POST MOUNT	20	\$ 28.50	\$ 570.00-
W16-2P	18 X 12	"500 FEET" PLAQUE	BLACK/YELLOW	TY IV, H/I PRISM.		12	\$ 6.17	\$ 74.04-
W20-3	30 X 30	ROAD CLOSED	BLACK/YELLOW	TY IV, H/I PRISM.		6	\$ 25.60	\$ 153.60-
N/A	30 X 30	"FLOOD AREA AHEAD"	BLACK/YELLOW	TY IV, H/I PRISM.	DIAMOND SHAPE	4	\$ 25.60	\$ 102.40-

SUBTOTAL FINISHED SIGNS

\$ 4703.34 \$4953.4

TOTAL COST FINISHED SIGNS

\$ 15,997.46  
\$ 16,248.02

Bid Submitted By: *Down Associates, Inc.*

Authorized Signature: *[Signature]*

DOUGLAS COUNTY PUBLIC WORKS  
2014 COMBINED SIGN BID

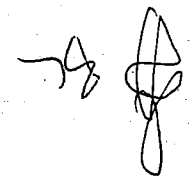

3/5/2014

FLUORESCENT SIGNS

MUTCD #	SIZE	DESCRIPTION	COLOR	SHEETING	REMARKS	# TO ORDER	UNIT COST	EXTENDED COST
M4-8	24 X 12	DETOUR	FLUORESCENT ORANGE	TY VIII OR BETTER		21	\$ 10.40	\$ 218.40
M4-8a	24 X 18	END DETOUR	FLUORESCENT ORANGE	TY VIII OR BETTER		4	\$ 15.60	\$ 62.40
M4-10L	48 X 18	DETOUR ARROW - LEFT	FLUORESCENT ORANGE	TY VIII OR BETTER		2	\$ 34.50	\$ 69.00
M4-10R	48 X 18	DETOUR ARROW - RIGHT	FLUORESCENT ORANGE	TY VIII OR BETTER		2	\$ 34.50	\$ 69.00
S3-1	30 X 30	SCHOOL BUS STOP AHEAD	FLUOR. YELLOW/GREEN	TY VIII OR BETTER	FLUORESCENT YEL/GREEN	4	\$ 34.00	\$ 136.00
W1-7	60 X 30	TWO-DIRECTION LARGE ARROW	FLUORESCENT YELLOW	TY VIII OR BETTER	FLUORESCENT YELLOW	4	\$ 74.62	\$ 298.48
W8-1	36 X 36	BUMP	FLUORESCENT ORANGE	TY VIII OR BETTER		5	\$ 46.80	\$ 234.00
W8-4	36 X 36	SOFT SHOULDER	FLUORESCENT ORANGE	TY VIII OR BETTER		6	\$ 46.80	\$ 280.80
W8-8	36 X 36	ROUGH ROAD	FLUORESCENT ORANGE	TY VIII OR BETTER		1	\$ 46.80	\$ 46.80
W8-9	36 X 36	LOW SHOULDER	FLUORESCENT ORANGE	TY VIII OR BETTER		8	\$ 46.80	\$ 374.40
W8-11	36 X 36	UNEVEN LANES	FLUORESCENT ORANGE	TY VIII OR BETTER		8	\$ 46.80	\$ 374.40
W20-1	36 X 36	ROAD WORK AHEAD	FLUORESCENT ORANGE	TY VIII OR BETTER		21	\$ 46.80	\$ 982.80
W20-1	48 X 48	ROAD WORK AHEAD	FLUORESCENT ORANGE	TY VIII OR BETTER		4	\$ 92.00	\$ 368.00
W20-2	48 X 48	DETOUR AHEAD	FLUORESCENT ORANGE	TY VIII OR BETTER		6	\$ 92.00	\$ 552.00
W20-2	48 X 48	DETOUR 500 FT	FLUORESCENT ORANGE	TY VIII OR BETTER		4	\$ 92.00	\$ 368.00
W20-3	48 X 48	"ROAD CLOSED"	FLUORESCENT ORANGE	TY VIII OR BETTER	2 LINES	4	\$ 92.00	\$ 368.00
W20-3	48 X 48	ROAD CLOSED 500 FT	FLUORESCENT ORANGE	TY VIII OR BETTER		5	\$ 92.00	\$ 460.00
W20-4	36 X 36	"ONE LANE ROAD AHEAD"	FLUORESCENT ORANGE	TY VIII OR BETTER	3 LINES	14	\$ 46.80	\$ 655.20
W21-5	36 X 36	SHOULDER WORK	FLUORESCENT ORANGE	TY VIII OR BETTER		8	\$ 46.80	\$ 374.40
N/A	48 X 48	"TRUCKS TURNING"	FLUORESCENT ORANGE	TY VIII OR BETTER	2 LINES	4	\$ 92.00	\$ 368.00

TOTAL COST FLUORESCENT SIGNS \$6,660.32

CUT OUT LETTERING

SERIES	SIZE	DESCRIPTION	CHARACTERS	COLOR	SHEETING	REMARKS	# TO ORDER (PKG)*	UNIT COST	EXTENDED COST
SERIES D	10"	NUMBER "1"	25	BLACK	TY IV, H/I PRISM.	PRESSURE SENSITIVE	1	\$	\$
SERIES D	10"	NUMBER "4"	25	BLACK	TY IV, H/I PRISM.	PRESSURE SENSITIVE	1	\$	\$
SERIES C	8"	NUMBER "4"	25	YELLOW	TY IV, H/I PRISM.	PRESSURE SENSITIVE	1	\$	\$

\* NOTE: \*ASSUMING EACH PACKAGE CONTAINS 25 CHARACTERS

TOTAL COST CUT OUT LETTERING \$ No bid

Bid Submitted By: *Osburn Associates, Inc.*

Authorized Signature: *[Signature]*

DOUGLAS COUNTY PUBLIC WORKS  
2014 COMBINED SIGN BID

3/5/2014

STEEL POSTS

LENGTH	WT./FT.	TYPE	REMARKS	# TO ORDER	UNIT COST	EXTENDED COST
7'	1.12#/FT.	STEEL DELINEATOR POST	GREEN ENAMEL	150	\$	\$
7'	3#/FT.	STEEL	GREEN ENAMEL	150	\$	\$
8'	3#/FT.	STEEL	GREEN ENAMEL	60	\$	\$
10'	3#/FT.	STEEL	GREEN ENAMEL	20	\$	\$
TOTAL COST STEEL POSTS						\$ <i>no bid</i>

TELESPAR POSTS

LENGTH	DIMENSION	TYPE	REMARKS	REMARKS	# TO ORDER	UNIT COST	EXTENDED COST
10'	1-1/2" SQUARE		14 GAUGE		10	\$	\$
10'	1-3/4" SQUARE		14 GAUGE		100	\$	\$
12'	1-3/4" SQUARE		14 GAUGE		75	\$	\$
3'	2" SQUARE		12 GAUGE	TUBULAR BASE	200	\$	\$
TOTAL COST TELESPAR POSTS							\$ <i>no bid</i>

MISCELLANEOUS ITEMS  
AWARDED ON ITEM BY ITEM BASIS

SIZE	DESCRIPTION	REMARKS	# TO ORDER	UNIT COST	EXTENDED COST			
4" X 50 YD	TEMP. PVMT MARKING TAPE, TY 2, YELLOW	FOILBACK (1 BOX @ 2 ROLLS EACH)	10	\$	\$ <i>no bid</i>			
MUTCD #	SIZE	DESCRIPTION	COLOR	SHEETING	REMARKS	# TO ORDER	UNIT COST	EXTENDED COST
OM3-L	12 X 36	OM3 LEFT RE-FACE	BLACK/YELLOW	TY IV, H/I PRISM.	SHEETING ONLY - NO BLANK	10	\$ 4.83	\$ 48.30
OM3-R	12 X 36	OM3 RIGHT RE-FACE	BLACK/YELLOW	TY IV, H/I PRISM.	SHEETING ONLY - NO BLANK	10	\$ 4.83	\$ 48.30
TOTAL MISC. ITEMS								\$ 96.60

Bid Submitted By: *Osborn Associates, Inc.*

Authorized Signature: *[Signature]*

3" YELLOW STRIPE (TYPICAL)  
 3 - 9/16" BLACK STRIPE (TYPICAL)

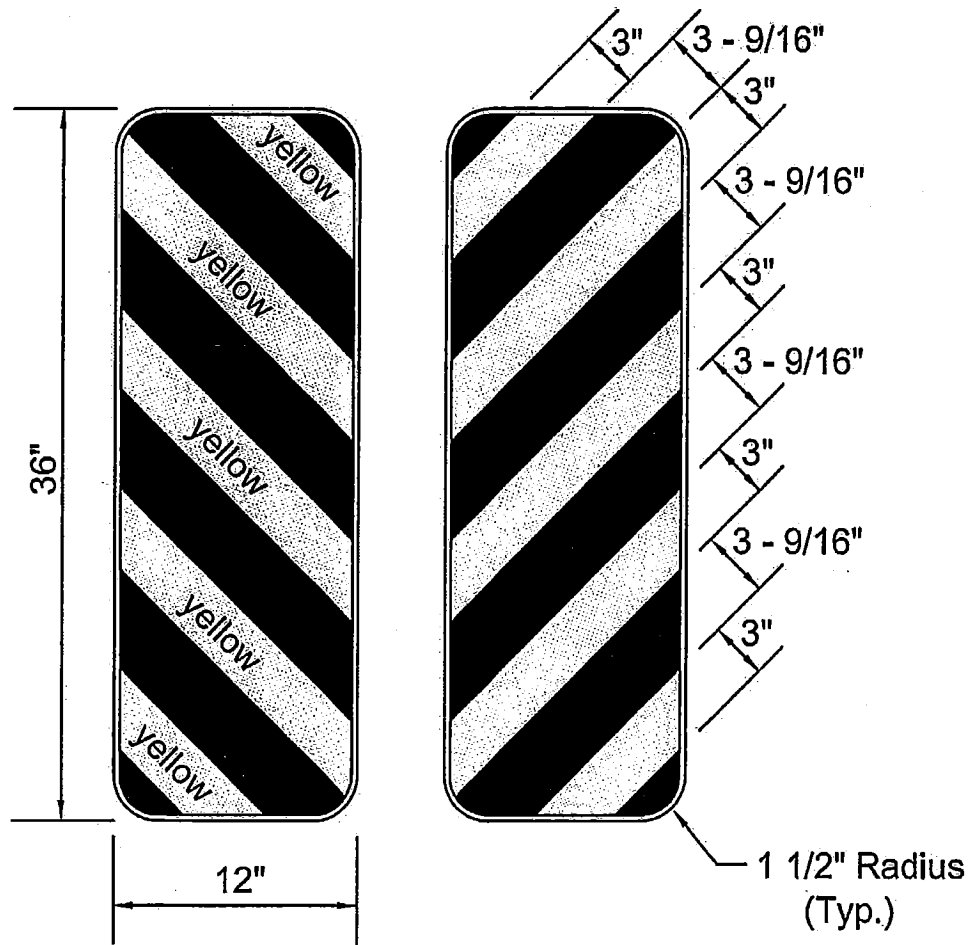

EXAMPLE: OM-3 LEFT AND RIGHT  
 SIZE: 12" X 36", BLACK AND YELLOW  
 STRIPE WIDTH: THE STRIPE WIDTHS SUPPLIED  
 SHOULD CONFORM TO THOSE  
 SPECIFIED ABOVE.



*Vulcan Signs*

**DOUGLAS COUNTY, KANSAS**

\*\*\*\*\*

FY 2014

SPECIFICATIONS AND CONTRACT DOCUMENTS

FOR

**SIGNS AND ACCESSORIES**

**BID NO. 14-F-0002**

\*\*\*\*\*

**DOUGLAS COUNTY, KANSAS**

**SPECIFICATIONS AND CONTRACT DOCUMENTS**

**FOR**

**PUBLIC WORKS DEPARTMENT**

**SIGNS AND ACCESSORIES**

**BID NO. 14-F-0002**

**BY**

**THE DOUGLAS COUNTY COMMISSIONERS**

**Mike Gaughan**  
Member

**Jim Flory**  
Member

**Nancy Thellman**  
Chairman

**Jamie Shew**  
County Clerk

**Keith A. Browning, P.E.**  
Director of Public Works



DOUGLAS COUNTY DEPARTMENT OF PUBLIC WORKS

BID NO. 14-F-0002

**NOTICE TO BIDDERS**

Notice is hereby given that sealed bids for the purchase of SIGNS AND ACCESSORIES, by the Douglas County Public Works Department, will be received in the office of the Douglas County Clerk, 1100 Massachusetts, Courthouse, Lawrence, Kansas, 66044 until 3:15 P.M., Tuesday, April 1, 2014, then publicly opened in the office of the Douglas County Clerk.

Bids must be submitted on forms provided by either the Douglas County Public Works Department, 1242 Massachusetts Street, Lawrence, Kansas or on the Internet at [www.demandstar.com](http://www.demandstar.com). The bids shall be submitted in sealed envelopes, addressed to the Office of the County Clerk, Courthouse, 1100 Massachusetts Street, Lawrence, Kansas 66044, upon which is clearly written or printed "Signs and Accessories", along with the name and address of the bidder. Any bid received by the Office of the County Clerk after the closing date and time will be returned unopened. Faxed bids will not be accepted. Douglas County is not responsible for the lost or misdirected bids, whether lost or misdirected by the postal or courier service of the bidder or the Douglas County mail room.

The awarded bidder shall agree to offer the prices and the terms and conditions herein to other government agencies who wish to participate in a cooperative purchase program with Douglas County. Other agencies will be responsible for entering into separate agreements with the awarded bidder and for all payments thereunder.

The Douglas County Department of Public Works reserves the right to reject any or all bids, or portions of bids, waive technicalities, and to purchase the items, which in the opinion of the Board, are best suited for the use intended.

Dated: March 10, 2014

DEPARTMENT OF PUBLIC WORKS  
DOUGLAS COUNTY, KANSAS  
Keith A. Browning, P.E.  
Director of Public Works

Published: Thursday, March 13, 2014  
Sunday, March 16, 2014

cc: Lawrence Journal World  
Board of County Commissioners  
County Clerk  
County Administrator  
County Shop  
Public Works Accounting  
Purchasing Department  
File

## DOUGLAS COUNTY PUBLIC WORKS DEPARTMENT

Bid No. 14-F-0002  
Signs and Accessories  
FY 2014

### Instructions to Bidders

1. It is the intent of Douglas County to purchase the various Signs and Accessories listed in this brochure.
2. Proposals must be submitted on forms provided by either the Douglas County Public Works Department, 1242 Massachusetts Street, Lawrence, Kansas or Demand Star @ [www.demandstar.com](http://www.demandstar.com). Specifications and bid requirements are included in these documents. The proposal must be left intact and will be the only form accepted as a bid by the Board of County Commissioners.
3. Bidders shall show unit prices for each item listed, shall extend all unit prices and total all extensions. All prices shall be F.O.B. Lawrence, Kansas. The County is not subject to City or State Sales Tax.
4. The Devices specified shall conform to the Manual on Uniform Traffic Control Devices, latest edition, as approved by the Federal Highway Administrator as part of the National Standard for all Highways, unless otherwise indicated in the specifications.
5. Bidders shall specify delivery date. Delivery date will be considered, as well as total price, in the selection of the successful bidder. Liquidated damages in the amount of 1% per day of the total bid price of items not received by the specified delivery date will be charged.
6. The supplier must notify Douglas County 48 hours prior to delivery. Douglas County reserves the right to refuse any shipment if proper advance notice is not received.
7. The back face of all finished signs shall be permanently marked with the producers name and year of manufacture. The size of the identification shall be no larger than 4" X 2", unless previously approved by the County Engineer.
8. The awarded bidder shall agree to offer the prices and the terms and conditions offered herein to other governmental agencies who wish to participate in a cooperative purchase program with Douglas County. All other agencies contracting with any vendor shall be responsible for entering into separate agreements and for all payments thereunder.
9. Bids must be sealed and received in the Douglas County Clerk's Office, Douglas County Courthouse, 1100 Massachusetts, Lawrence, Kansas 66044, prior to 3:15 P.M., Tuesday, April 1, 2014. Faxed bids will not be accepted. The County is not responsible for lost or misdirected bids, whether lost or misdirected by the postal or courier service of the bidder or the County mail room. Any bids received after the time specified will be returned unopened.
10. The County reserves the right to reject any or all bids or waive technicalities and to purchase the items which, in the opinion of the Board of County Commissioners, are best suited to the work for which they are intended. The award will be made to the lowest and best bidder for each group of items specified (finished signs, fluorescent signs, cut out lettering, steel posts and telespar posts). Miscellaneous items will be awarded on an item by item basis.

### Instructions to Bidders (continued)

11. All sheeting used on sign faces shall be TYPE IV High Intensity Prismatic Grade or TYPE VIII or better for Fluorescent Orange, Yellow and Yellow/Green sheeting meeting the requirements stated in Section 2201, "Retroreflective Sheeting", of the KDOT Standard Specifications, 2007 Edition, unless otherwise indicated in the bid documents. A copy of this specification is attached to this proposal, or may be viewed at <http://www.ksdot.org/burconsmain/specprov/2007/2201.pdf>. A list of pre-qualified materials can be found at <http://www.ksdot.org/burmatres/pql/default.asp>.
12. The chip and seal markers shall meet the requirements stated in Special Provision 07-22004 (Temporary Raised Pavement Markers) in Section 2200, "Reflective Materials and Accessory Items", of the KDOT Standard Specifications, 2007 Edition. A copy of this Special Provision is attached to this proposal, or may be viewed at <http://www.ksdot.org/burconsmain/specprov/2007/pdf/07-22004.pdf>.
13. All sign blanks shall be a minimum of .080 gauge aluminum (except those greater than 36" in any dimension, which shall be 10 gauge), unless otherwise specified.

STANDARD TERMS AND CONDITIONS  
DOUGLAS COUNTY, KANSAS

1. SCOPE: The following terms and conditions shall prevail unless otherwise modified by Douglas County within this bid document. Douglas County reserves the right to accept or reject any or all bids received, waive technicalities, and to purchase the products, which in the opinion of the Board of County Commissioners, is best suited to the work for which it is intended.
  
2. DEFINITIONS AS USED HEREIN:
  - a. The term "bid request" means a solicitation of a formal sealed bid.
  - b. The term "bid" means the price offered by the bidder.
  - c. The term "bidder" means the offer or vendor.
  - d. The term "County" means Douglas County, Kansas.
  - e. The term "Board of County Commissioners or "BOCC" means the governing body of Douglas County, Kansas.
  - f. The term "awarded bidder" means any bidder awarded a contract pursuant to its bid.
  
3. COMPLETING BID: Bids must be submitted only on the forms (or reproductions thereof) provided in this document. All information must be legible. Any and all corrections and/or erasures must be initialed. Each bid sheet must be signed by the authorized bidder and all required information must be provided.
  
4. CONFIDENTIALITY OF BID INFORMATION: Each bid must be sealed and submitted in an envelope clearly marked "SIGNS AND ACCESSORIES" to provide confidentiality of the bid information prior to the bid opening. Supporting documents and/or descriptive literature may be submitted with the bid. Do not indicate bid prices on literature.

All bids and supporting bid documents become public information after the bid opening and are available for public inspection by the general public in accordance with the Kansas Open Records Act.
  
5. ACCURACY OF BID: Each bid is publicly opened in the presence of the Douglas County Clerk. It is required that any and all information presented is accurate and/or will be that by which the bidder will perform if awarded the contract. If there is a discrepancy between the unit price and extended total, the unit price will prevail.
  
6. SUBMISSION OF BID: Bids must be sealed and received in the Douglas County Clerk's Office, Douglas County Courthouse, 1100 Massachusetts, Lawrence, Kansas 66044, prior to 3:15 P.M., Tuesday, April 1, 2014. Faxed bids will not be accepted. The County is not responsible for lost or misdirected bids, whether lost or misdirected by the postal or courier service of the bidder or the County mail room.
  
7. ADDENDA: All changes in connection with this bid will be issued in the form of a written addendum. Signed acknowledgment of receipt of each addendum must be submitted with the bid.

STANDARD TERMS AND CONDITIONS (continued)

8. LATE BIDS, CHANGES OR WITHDRAWALS: Bids received after the deadline designated in this bid document shall not be considered and shall be returned unopened.

Bids may be changed or withdrawn prior to the bid opening. All such transactions must be submitted in writing and received by the County Clerk's Office prior to the bid deadline. Changes or withdrawals may be made after the bid deadline only with the approval of the Board of County Commissioners. After bid opening, no changes in bid prices or other provisions of bids prejudicial to the interest of the County or fair competition shall be permitted.

9. BIDS BINDING: All bids submitted shall be binding upon the bidder if accepted by the County within fifteen (15) calendar days after the bid opening.

10. EQUIVALENT BIDS: When brand or trade names are used in the bid invitation, it is for the purpose of item identification and to establish standards for quality, style and features. Bids on equivalent items of substantially the same quality, style and features are invited unless items are marked "No Substitute." Equivalent bids must be accompanied by descriptive literature and/or specifications to receive consideration. Demonstrations and/or samples may be required and shall be supplied at no charge to the County.

11. NEW MATERIALS, SUPPLIES OR EQUIPMENT: Unless otherwise specified, all materials, supplies or equipment offered by a bidder shall be new, unused, of recent manufacture, first class in every respect and suitable for their intended purpose. All equipment shall be assembled, and ready for operation when delivered.

12. WARRANTY: Supplies or services furnished as a result of this bid shall be covered by the most favorable commercial warranties, expressed or implied, that the bidder and/or manufacturer gives to any customer. The rights and remedies provided herein are in addition to and do not limit any rights afforded to the County by any other clause of this bid. The County reserves the right to request from bidders a separate manufacturer certification of all statements made in the proposal.

13. METHOD OF AWARD AND NOTIFICATION: Bids will be evaluated and the award made to the lowest and best, responsive and responsible bidder(s) whose bid conforms to the specifications and whose bid is considered to be the best value in the opinion of the Board of County Commissioners.

The County reserves the right to accept or reject any or all bids and any part of a bid and to waive informalities, technical defects, and minor irregularities in bids received. The award will be made to the lowest and best bidder for each group of items specified (finished signs, fluorescent signs, cut out lettering, steel posts and telespar posts). Miscellaneous items will be awarded on an item by item basis.

The signed bid shall be considered an offer on the part of the bidder; such offer shall be deemed accepted upon issuance by the County of a Purchase Order or other contractual document.

STANDARD TERMS AND CONDITIONS (continued)

14. DELIVERY TERMS: All deliveries shall be F.O.B. Lawrence, Kansas and all freight charges shall be included in the bid price. Delivery date shall be considered as a cost factor in the determination of award.
15. DAMAGED AND/OR LATE SHIPMENTS: The County has no obligation to accept damaged shipments and reserves the right to return at the vendor's expense damaged merchandise even though the damage was not apparent or discovered until after receipt of the items. The Vendor is responsible to notify the Douglas County Department of Public Works of any late or delayed shipments. The County reserves the right to cancel all or any part of an order if the shipment is not made as promised.
16. CREDIT TERMS: Bidder shall indicate all discounts for full and/or prompt payment. Discounts offered shall be computed from date of receipt of correct invoice or receipt and acceptance of products, whichever is later.
17. SELLERS INVOICE: Invoices shall be prepared and submitted in at least two copies to the address shown on the Purchase Order or bid document. Separate invoices are required for each Purchase Order or bid document. Invoices shall contain the following information: Purchase order number and date, bid number, item number, description of supplies or services, sizes, unit of measure, quantity, unit price and extended totals.
18. TAX EXEMPT: The County and its agencies are exempt from State and local sales taxes by K.S.A. 79-3606, as amended. Situs of all transactions under the order(s) that shall be derived from this request shall be deemed to have been accomplished within the State of Kansas.
19. SAFETY: All practices, materials, supplies and equipment shall comply with the Federal Occupational Safety and Health Act, as well as any pertinent Federal, state and/or local safety or environmental codes.
20. DISCLAIMER OF LIABILITY: The County, or any of its agencies, will not hold harmless or indemnify any bidder for any liability whatsoever.
21. HOLD HARMLESS: The awarded bidder agrees to protect, defend, indemnify and hold the Board of County Commissioners, its officers, employees and agents free and harmless from and against any and all losses, penalties, damages, settlements, costs, charges, professional fees or other expenses or liabilities of every kind and character arising out of or relating to any and all claims, liens, demands, obligations, actions, proceedings or causes of action of every kind and character in connection with or arising directly or indirectly out of this agreement and/or the performance hereof. Without limiting the generality of the foregoing, and all such claims, etc., relating to personal injury, infringement of any patent, trademark, copyright (or application for any thereof) or of any other tangible or intangible personal or property right, or actual or alleged violation of any applicable statute, ordinance, administrative order, rule or regulation, or decree of any court, shall be included in the indemnity hereunder. The awarded bidder further agrees to investigate, handle, respond to, provide defense for and defend any such claims, etc., at his/her sole expense and agrees to bear all other costs and expenses related thereto, even if such claim is groundless, false or fraudulent.

STANDARD TERMS AND CONDITIONS (continued)

22. LAW GOVERNING: All contractual agreements shall be subject to, governed by, and construed according to the laws of the State of Kansas.
23. ANTI-DISCRIMINATION CLAUSE: No bidder on this request shall in any way, directly or indirectly, discriminate against any person because of age, race, color, handicap, sex, national origin, or religious creed.





**SECTION 2201**

**RETROREFLECTIVE SHEETING**

**2201.1 DESCRIPTION**

This specification covers Type I and all Types of High Intensity retroreflective sheeting. This includes both non-exposed glass bead lens and microprismatic sheeting.

**2201.2 REQUIREMENTS**

a. **General.** Provide retroreflective sheeting that complies with ASTM D 4956 (latest revision) except for the color limits as specified in subsection 2201.2b. The type to be provided will be shown in the Contract Documents. Types and classes are as defined in ASTM D 4956.

b. **Color.** The colors of the retroreflective sheeting are white, yellow, red, orange, green, blue, brown, fluorescent orange, fluorescent yellow, and fluorescent yellow-green. Provide colors that comply with the chromaticity limits as shown in TABLE 2201-1 for both Type I and Type III sheeting and TABLE 2201-2 for all other Types of High Intensity sheeting (Type IV through Type XI). Provide fluorescent colors that comply with the chromaticity limits in ASTM D 4956 (latest revision).

TABLE 2201-1: COLOR SPECIFICATION (Type I and Type III)								
COLOR	Chromaticity Coordinates							
	1		2		3		4	
	x	y	x	y	x	y	x	y
White	0.310	0.313	0.338	0.342	0.325	0.355	0.300	0.327
Yellow	0.496	0.503	0.545	0.454	0.505	0.433	0.460	0.474
Red	0.574	0.337	0.665	0.345	0.708	0.292	0.613	0.297
Orange	0.558	0.352	0.636	0.364	0.570	0.429	0.506	0.404
Green	0.130	0.387	0.180	0.410	0.140	0.521	0.098	0.490
Blue	0.138	0.065	0.112	0.135	0.160	0.170	0.176	0.120
Brown	0.430	0.340	0.610	0.390	0.550	0.450	0.430	0.390

TABLE 2201-2: COLOR SPECIFICATION (Type IV - Type XI)								
COLOR	Chromaticity Coordinates							
	1		2		3		4	
	x	y	x	y	x	y	x	y
White	0.310	0.313	0.328	0.331	0.316	0.345	0.300	0.327
Yellow	0.515	0.484	0.545	0.454	0.505	0.433	0.475	0.460
Red	0.586	0.324	0.664	0.336	0.708	0.292	0.613	0.297
Orange	0.558	0.352	0.636	0.364	0.570	0.429	0.506	0.404
Green	0.130	0.387	0.180	0.410	0.155	0.478	0.107	0.457
Blue	0.138	0.065	0.112	0.135	0.160	0.170	0.176	0.120
Brown	0.430	0.340	0.610	0.390	0.550	0.450	0.430	0.390

c. **Conformable Retroreflective Sheeting.** Provide High Intensity retroreflective sheeting that has a conformable aluminum foil backing with an aggressive pressure sensitive adhesive. This material is designed for application to moderately rough or porous metal, wood or masonry surfaces. Provide material that complies with ASTM D 4956 (latest revision) with the following exceptions and additions:

- (1) Conformable aluminum backing thickness - 0.005 inches to 0.010 inches.
- (2) Follow all manufacturers' recommendations for application procedures and temperatures.

**2201.3 MANUFACTURER WARRANTY**

The following warranty conditions apply only to the retroreflective sheeting manufacturer. Provide a product warranty for a minimum period of 10 years on all Types of High Intensity retroreflective sheeting, for placement on permanent signing. Failure to comply with this warranty may be cause for removal from the prequalified list.

The High Intensity retroreflective sheeting warranty must comply with the following requirements and obligations:

- **Certification:** Submit with each lot or shipment, a certification which states that the material supplied is subject to and complies with the requirements. Include in the certification, the manufacturer's office, address, phone number and the contact for potential claims under the provisions of this warranty. Provide documentation as to which signs were fabricated from each lot.
- **Field Performance:** Field Performance applies to retroreflective sheeting applied to sign blank materials or overlaid on existing signs. The field performance obligation period begins with the date of erection. The sheeting is considered unsatisfactory if it has deteriorated due to natural causes to the extent that the sign is ineffective for its intended purpose when viewed from a moving vehicle under normal day and night driving conditions or shows any of the following defects:
  - Cracking discernible with the unaided eye from a driver's position at a distance of 50 feet or greater from the sign;
  - More than 25% loss of specular gloss and cracking, scaling, pitting, orange peel, delamination, edge lifting or curling;
  - Peeling in excess of 3/8 inch;
  - Shrinkage in excess of 3/16 inch total per yard of sheeting width;
  - Fading or loss of color to the extent that retroreflective sheeting color fails to comply with the subsection 2201.2b., or;
  - Loss of retroreflectivity reducing the coefficient of retroreflection as measured by a retroreflectorimeter to less than the minimum specified in TABLE 2201-3 at 0.2° observation and -4° entrance angles. Make all measurements after cleaning the sign.

Sheeting Color	Min. Coefficient
White	200
Yellow	136
Green	36
Red	36
Blue	16
Brown	9

**Defective Material Replacement:** When traffic signs with High Intensity sheeting fail to comply with the field performance requirements, re-sheet or replace the signs at no cost to the Douglas County for materials and labor. Employ a contractor qualified by the KDOT to perform signing work. Install highway signs, as shown in the Contract Documents and the M.U.T.C.D. (latest edition) and provide proper traffic control.

Replace all defective material within 60 days after written notification by Douglas County. Signs not corrected within 60 days, will be removed and replaced by Douglas County. Signs removed by Douglas County will be placed in storage for inspections by the manufacturer, and the manufacturer will be billed for all costs of replacement of the sheeting.

When more than 25% of the signs within a lot fail to comply with the requirements, replace all signs made from that lot.

**2201.4 PREQUALIFICATION**

Manufacturers desiring to provide material under this specification are to submit prequalification samples of each type, class and color covered by this specification which they wish to prequalify. Each sample consists of 3 pieces 24 inches square.

Forward the prequalification samples to the Engineer of Tests, Materials and Research Center, 2300 Van Buren, Topeka, KS 66611. Samples will be tested for compliance with all requirements of this specification. Each Manufacturer will be notified of the test results.

If the prequalification samples of retroreflective sheeting comply with this specification, the product will be placed on a list of prequalified products maintained by the Bureau of Materials and Research. No retroreflective sheeting will be used on KDOT projects unless it has been prequalified. Manufacturers will be required to requalify at intervals determined by the Engineer of Tests.

Testing and evaluation by KDOT may be waived if complete testing has been performed on the identical product by AASHTO National Transportation Product Evaluation Program (NTPEP). Forward an official copy of the test report along with evidence that the product referenced is identical to that submitted for prequalification, to the Engineer of Tests for evaluation.

#### 2201.5 METHODS OF TESTS

All tests will be conducted in accordance with ASTM D 4956 with the exception of artificial weathering. Artificial weathering will be conducted according to ASTM G 155, Cycle 1, with the following additions and exceptions:

- At the end of each 20 hour cycle, the panels will be placed in a cold cabinet at approximately 0°F for one hour. After removal from the cold cabinet, panels will be returned to the weatherometer to await the start of the next cycle.
- Water used in the weatherometer will be city water softened to a total hardness content of less than 5 parts per million expressed as calcium carbonate.

#### 2201.6 BASIS OF ACCEPTANCE

##### a. Permanent Sheeting.

- (1) Prequalification as required by subsection 2201.4.
- (2) Satisfactory results of tests conducted at MRC. Each lot of sheeting will be sampled at destination by a representative of the KDOT and will be subjected to a visual examination and tested for physical properties as necessary to verify that the sheeting complies with this specification.
- (3) Receipt of the warranty certification as specified in subsection 2201.3 by the County Engineer.

b. Temporary Sheeting. Retroreflective sheeting used to manufacture temporary traffic control signs will be accepted on the basis of a certification prepared by the contractor stating that the retroreflective sheeting used to manufacture the signs was prequalified under this specification, and visual inspection by the Engineer for condition and other requirements.

**KANSAS DEPARTMENT OF TRANSPORTATION  
SPECIAL PROVISION TO THE  
STANDARD SPECIFICATIONS, EDITION 2007**

Add a new SECTION in DIVISION 2200:

**TEMPORARY RAISED PAVEMENT MARKERS**

**1.0 DESCRIPTION**

This specification covers temporary raised pavement markers for lane marking and delineation. This includes both Flexible and Rigid (Types I and II) markers for use on both Portland cement concrete and asphalt surfaces.

**2.0 REQUIREMENTS**

**a. General.**

(1) Provide temporary reflective markers as shown in the Contract Documents. The markers shall be readily visible at night, from a minimum of 300 feet, when viewed with high beam automobile headlamps. Prior to use, markers must be approved by the Engineer. The marker shall be the same color as the reflective elements. All markers shall be capable of sustaining 2000 direct wheel-over impacts at 60 mph without losing adhesion to the roadway or sustaining damage to the marker body.

(2) Provide Flexible temporary raised pavement markers which consist of an L-shaped flexible polyurethane body with prismatic reflective sheeting on both faces. The reflective sheeting shall be a minimum of 1 square inch spread over the 4" wide marker. The markers shall have minimum dimensions of 4 inches wide x 2 inches high with a 1 inch wide base leg. Thickness of the body shall be a minimum of 0.06 inches. The marker shall have an affixed pressure sensitive adhesive, protected by a release paper, for application to the pavement surface. Attach a clear flexible plastic cover to the vertical section of the marker to protect the reflective material during surfacing operations. The cover shall withstand the work and be easily removed after the operation. The markers shall not cause any damage to the automobile.

(3) Provide Rigid (Type I) temporary raised pavement markers constructed of traffic bearing high impact plastic with prismatic reflective faces. The base of the markers shall have minimum dimensions of 2.5 inches wide, 4 inches long and 0.4 inches high. The base of the marker shall be flat. Markers shall be reflectorized with one or more reflective faces on each side using either an acrylic retroreflector, or retroreflective sheeting. Each face shall contain a minimum of 0.38 square inches of reflective surface. The adhesive used shall not stain the pavement and will allow the markers to be easily removed without damage to the roadway surface. If the marker is self adhesive, it shall be pre-coated with an affixed pressure sensitive adhesive, protected by a release paper.

(4) Provide Rigid (Type II) or brick markers constructed of traffic bearing high impact plastic with prismatic reflective faces. The marker shall have minimum dimensions of 2.5 inches high, 7.5 inches wide and 13 inches long. The base of the marker shall be flat. Markers shall be reflectorized with two or more reflective faces on each side using either an acrylic retroreflector, or retroreflective sheeting. Each face shall contain a minimum of 3.75 square inches of reflective surface. The adhesive used will allow the markers to be removed without damage to the roadway surface. If the marker is self adhesive, it shall be pre-coated with an affixed pressure sensitive adhesive, protected by a release paper.

**b. Retroreflectivity.** Provide markers in white or yellow which comply with the minimum requirements shown in TABLE 1:

<b>TABLE 1: RETROREFLECTIVITY REQUIREMENTS</b>	
<b>Color</b>	<b>Millicandelas/sq m/lux (min.)<sup>a</sup> (measured at 0.2° observation angle and 0° entrance angle)</b>
<b>White</b>	<b>3.0</b>
<b>Yellow</b>	<b>1.8</b>

<sup>a</sup> Flexible markers must meet these requirements before and after durability testing

c. **Color.** Markers shall be white or yellow in color, solid throughout, and match the color of the lane line on which the marker will be placed under both daylight and nighttime conditions.

d. **Durability.** Flexible markers, as defined in subsection 2.0a(2), must withstand 2000 revolutions on a small-wheel circular track. 12 markers of each color will be tested. No more than 3 markers shall move from their original position during testing.

### 3.0 TEST METHODS

a. **Retroreflectivity.** Test in accordance with ASTM E 809.

b. **Durability.** Test in accordance with ASTM E 660, with the following variations:

(1) Mount two opposite wheels with 11 x 6.00 x 5 nylon smooth non-pattern tread tires with a total load of 50 pounds on each tire. Maintain tire pressure at 25 psi. Mount the wheels perpendicular to the specimens and toe out 2° to produce a slight abrading action.

(2) Apply markers, according to the manufacturer's recommendations, to 6 inch diameter dense grade asphalt concrete cores, which have been compacted at 3000 psi for 2 minutes.

### 4.0 PREQUALIFICATION

Manufacturers wishing to supply markers to KDOT projects must have their product tested by the AASHTO National Transportation Product Evaluation Program (NTPEP). Submit 12 flexible markers or 2 rigid markers of each color for which prequalification is requested, and an official copy of the NTPEP test report to the Engineer of Tests, Materials and Research Center, 2300 Van Buren, Topeka, KS 66611. Include evidence that the product offered is identical to that described in the test report, and information regarding the recommended adhesive, if any is required. Prequalification will be based on satisfactory compliance of NTPEP results and laboratory testing with subsection 2.0.

### 5.0 BASIS OF ACCEPTANCE

Prequalification as required by subsection 4.0.

Receipt and approval of a Type C certification as specified in DIVISION 2600.

Visual inspection for condition and dimensional requirements.

09-06-12 M&R (SML/KJS)  
Jan-13 Letting

DOUGLAS COUNTY PUBLIC WORKS  
2014 COMBINED SIGN BID

3/5/2014

FINISHED SIGNS

MUTCD #	SIZE	DESCRIPTION	COLOR	SHEETING	REMARKS	# TO ORDER	UNFT COST	EXTENDED COST
M1-6	24 X 24	DOUGLAS COUNTY	YELLOW/BLUE	TY IV, H/I PRISM.	NO ROUTE NUMBER	10	\$ 18.78	\$ 187.80
M1-6	24 X 24	DOUGLAS COUNTY 1	YELLOW/BLUE	TY IV, H/I PRISM.	ROUTE MARKER	4	\$ 19.85	\$ 79.40
M1-6	24 X 24	DOUGLAS COUNTY 1S	YELLOW/BLUE	TY IV, H/I PRISM.	ROUTE MARKER	5	\$ 19.85	\$ 99.25
M1-6	24 X 24	DOUGLAS COUNTY 1W	YELLOW/BLUE	TY IV, H/I PRISM.	ROUTE MARKER	5	\$ 19.85	\$ 99.25
M1-6	24 X 24	DOUGLAS COUNTY 1E	YELLOW/BLUE	TY IV, H/I PRISM.	ROUTE MARKER	5	\$ 19.85	\$ 99.25
M1-6	24 X 24	DOUGLAS COUNTY 2	YELLOW/BLUE	TY IV, H/I PRISM.	ROUTE MARKER	5	\$ 19.85	\$ 99.25
M1-6	24 X 24	DOUGLAS COUNTY 3	YELLOW/BLUE	TY IV, H/I PRISM.	ROUTE MARKER	5	\$ 19.85	\$ 99.25
M1-6	24 X 24	DOUGLAS COUNTY 4	YELLOW/BLUE	TY IV, H/I PRISM.	ROUTE MARKER	4	\$ 19.85	\$ 79.40
M1-6	24 X 24	DOUGLAS COUNTY 6	YELLOW/BLUE	TY IV, H/I PRISM.	ROUTE MARKER	10	\$ 18.78	\$ 187.80
M1-6	24 X 24	DOUGLAS COUNTY 438	YELLOW/BLUE	TY IV, H/I PRISM.	ROUTE MARKER	7	\$ 19.81	\$ 138.67
M1-6	24 X 24	DOUGLAS COUNTY 442	YELLOW/BLUE	TY IV, H/I PRISM.	ROUTE MARKER	5	\$ 19.85	\$ 99.25
M1-6	24 X 24	DOUGLAS COUNTY 460	YELLOW/BLUE	TY IV, H/I PRISM.	ROUTE MARKER	10	\$ 18.78	\$ 187.80
M1-6	24 X 24	DOUGLAS COUNTY 1023	YELLOW/BLUE	TY IV, H/I PRISM.	ROUTE MARKER	10	\$ 18.78	\$ 187.80
M1-6	24 X 24	DOUGLAS COUNTY 1029	YELLOW/BLUE	TY IV, H/I PRISM.	ROUTE MARKER	10	\$ 18.78	\$ 187.80
M1-6	24 X 24	DOUGLAS COUNTY 1039	YELLOW/BLUE	TY IV, H/I PRISM.	ROUTE MARKER	7	\$ 19.81	\$ 138.67
M4-6	24 X 12	"END" - AUXILIARY SIGN	BLACK/WHITE	TY IV, H/I PRISM.		5	\$ 13.95	\$ 69.75
M6-1	21 X 15	DIRECTIONAL SIGN	BLACK/WHITE	TY IV, H/I PRISM.		10	\$ 8.94	\$ 89.40
OM2-2V	6 X 12	TYPE 2 OBJECT MARKER	YELLOW	TY IV, H/I PRISM.		400	\$ 2.50	\$ 1000.00
OM2-2V	6 X 12	TYPE 2 OBJECT MARKER	WHITE	TY IV, H/I PRISM.		50	\$ 2.50	\$ 125.00
OM3-L	12 X 36	OBJECT MARKER TYPE III - LEFT	BLACK/YELLOW	TY IV, H/I PRISM.	SEE PLAN DETAILS	254	\$ 11.47	\$ 2913.38
OM3-R	12 X 36	OBJECT MARKER TYPE III - RIGHT	BLACK/YELLOW	TY IV, H/I PRISM.	SEE PLAN DETAILS	250	\$ 11.47	\$ 2867.50
OM4-3	18 X 18	END OF ROAD MARKER	RED	TY IV, H/I PRISM.		24	\$ 9.15	\$ 219.60
R1-1	30 X 30	STOP SIGN	WHITE/RED	TY IV, H/I PRISM.		20	\$ 22.71	\$ 454.20
R1-2	30 X 30 X 30	YIELD	WHITE/RED	TY IV, H/I PRISM.		1	\$ 12.38	\$ 12.38
R1-3P	18 X 6	ALL WAY	WHITE/RED	TY IV, H/I PRISM.		8	\$ 3.33	\$ 26.64
R2-1	24 X 30	"SPEED LIMIT"	BLACK/WHITE	TY IV, H/I PRISM.	NO SPEED LIMIT NUMBER	7	\$ 18.05	\$ 126.35
R2-1-25	24 X 30	"SPEED LIMIT 25"	BLACK/WHITE	TY IV, H/I PRISM.		4	\$ 18.05	\$ 72.20
R2-1-40	24 X 30	"SPEED LIMIT 40"	BLACK/WHITE	TY IV, H/I PRISM.		5	\$ 18.05	\$ 90.25
R2-1-55	24 X 30	"SPEED LIMIT 55"	BLACK/WHITE	TY IV, H/I PRISM.		20	\$ 18.05	\$ 361.00
R5-1	30 X 30	"DO NOT ENTER"	WHITE/RED	TY IV, H/I PRISM.		2	\$ 22.56	\$ 45.12
R7-1	12 X 18	NO PARKING <—>	WHITE/RED	TY IV, H/I PRISM.	DOUBLE ARROW BELOW "NO PARKING"	5	\$ 5.85	\$ 29.25
R7-1	18 x 24	NO PARKING <—>	WHITE/RED	TY IV, H/I PRISM.	DOUBLE ARROW BELOW "NO PARKING"	4	\$ 5.85	\$ 23.40
R7-1L	12 x 18	NO PARKING <—	WHITE/RED	TY IV, H/I PRISM.	LEFT ARROW BELOW "NO PARKING"	4	\$ 5.85	\$ 23.40
R7-1L	18 x 24	NO PARKING <—	WHITE/RED	TY IV, H/I PRISM.	LEFT ARROW BELOW "NO PARKING"	7	\$ 10.83	\$ 75.81
R7-1R	12 x 18	NO PARKING —>	WHITE/RED	TY IV, H/I PRISM.	RIGHT ARROW BELOW "NO PARKING"	5	\$ 5.85	\$ 29.25
R7-1R	18 x 24	NO PARKING —>	WHITE/RED	TY IV, H/I PRISM.	RIGHT ARROW BELOW "NO PARKING"	2	\$ 14.99	\$ 29.98
R11-2	48 X 30	"ROAD CLOSED"	BLACK/WHITE	TY IV, H/I PRISM.	2 LINES	7	\$ 42.36	\$ 296.50
R11-3a	60 X 30	"ROAD CLOSED _ MILES AHEAD LOCAL TRAFFIC ONLY"	BLACK/WHITE	TY IV, H/I PRISM.	3 LINES	4	\$ 52.94	\$ 211.76
R12-1	24 X 30	"WEIGHT LIMIT _ TONS"	BLACK/WHITE	TY IV, H/I PRISM.		5	\$ 18.05	\$ 90.25
R12-5	24 X 36	"WEIGHT LIMIT _ TONS"	BLACK/WHITE	TY IV, H/I PRISM.	3 TIER W/ NO DISPLAYED # - "T" ONLY	10	\$ 21.66	\$ 216.00

SUBTOTAL FINISHED SIGNS

\$11,469.63

Bid Submitted By: Vulcan Signs

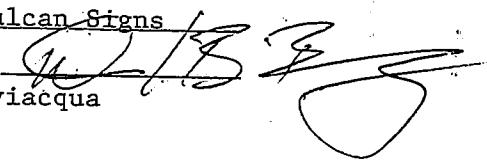
Authorized Signature: 

David B. Beviacqua

DOUGLAS COUNTY PUBLIC WORKS  
2014 COMBINED SIGN BID

3/5/2014

FINISHED SIGNS (CONTINUED)								
MUTCD #	SIZE	DESCRIPTION	COLOR	SHEETING	REMARKS	# TO ORDER	UNIT COST	EXTENDED COST
W1-1L	30 X 30	LEFT TURN ARROW	BLACK/YELLOW	TY IV, H/I PRISM.		4	\$ 22.56	\$ 90.24
W1-1L	48 X 48	LEFT TURN ARROW	BLACK/YELLOW	TY IV, H/I PRISM.		2	\$ 79.73	\$ 159.46
W1-1R	36 X 36	RIGHT TURN ARROW	BLACK/YELLOW	TY IV, H/I PRISM.		4	\$ 32.49	\$ 129.96
W1-1R	48 X 48	RIGHT TURN ARROW	BLACK/YELLOW	TY IV, H/I PRISM.		3	\$ 79.73	\$ 239.19
W1-2L	30 X 30	CURVE SIGN - LEFT	BLACK/YELLOW	TY IV, H/I PRISM.		2	\$ 22.56	\$ 45.12
W1-2L	36 X 36	CURVE SIGN - LEFT	BLACK/YELLOW	TY IV, H/I PRISM.		3	\$ 32.49	\$ 97.47
W1-2L	48 X 48	CURVE SIGN - LEFT	BLACK/YELLOW	TY IV, H/I PRISM.		2	\$ 79.73	\$ 159.46
W1-2R	30 X 30	CURVE SIGN - RIGHT	BLACK/YELLOW	TY IV, H/I PRISM.		5	\$ 22.56	\$ 112.80
W1-2R	36 X 36	CURVE SIGN - RIGHT	BLACK/YELLOW	TY IV, H/I PRISM.		4	\$ 32.49	\$ 129.96
W1-3R	30 X 30	REVERSE TURN SIGN - RIGHT	BLACK/YELLOW	TY IV, H/I PRISM.		1	\$ 22.56	\$ 22.56
W1-6	36 X 18	ONE-DIRECTION LARGE ARROW	BLACK/YELLOW	TY IV, H/I PRISM.		4	\$ 20.49	\$ 81.96
W1-6	48 X 24	ONE-DIRECTION LARGE ARROW	BLACK/YELLOW	TY IV, H/I PRISM.		3	\$ 33.87	\$ 101.61
W1-7	36 X 18	TWO-DIRECTION LARGE ARROW	BLACK/YELLOW	TY IV, H/I PRISM.		3	\$ 20.49	\$ 61.47
W1-7	48 X 24	TWO-DIRECTION LARGE ARROW	BLACK/YELLOW	TY IV, H/I PRISM.		5	\$ 33.87	\$ 169.35
W1-8	18 X 24	CHEVRON ALIGNMENT SIGN	BLACK/YELLOW	TY IV, H/I PRISM.		60	\$ 10.83	\$ 649.80
W2-4	30 X 30	T-INTERSECTION AHEAD	BLACK/YELLOW	TY IV, H/I PRISM.		3	\$ 22.56	\$ 67.68
W3-5	36 X 36	REDUCE SPEED LIMIT AHEAD 30	BL-WHITE/YELLOW	TY IV, H/I PRISM.		4	\$ 40.50	\$ 162.00
W3-5	36 X 36	REDUCE SPEED LIMIT AHEAD 40	BL-WHITE/YELLOW	TY IV, H/I PRISM.		5	\$ 40.50	\$ 202.50
W8-6	30 X 30	TRUCK CROSSING	BLACK/YELLOW	TY IV, H/I PRISM.		4	\$ 27.82	\$ 111.28
W8-17	30 X 30	SHOULDER DROP OFF (SYMBOL)	BLACK/YELLOW	TY IV, H/I PRISM.		7	\$ 22.56	\$ 157.92
W10-1	36" DIA	GRADE CROSSING ADVANCE WARNING	BLACK/YELLOW	TY IV, H/I PRISM.	(RAILROAD EMBLEM)	6	\$ 32.26	\$ 193.56
W11-8	36 X 36	EMERGENCY VEHICLE	BLACK/YELLOW	TY IV, H/I PRISM.		5	\$ 40.07	\$ 200.35
W11-8P	24 X 18	"FIRE STATION"	BLACK/YELLOW	TY IV, H/I PRISM.	TWO LINES	4	\$ 13.66	\$ 54.64
W13-1P	18 X 18	"20 MPH"	BLACK/YELLOW	TY IV, H/I PRISM.		5	\$ 9.15	\$ 45.75
W13-1P	18 X 18	"35 MPH"	BLACK/YELLOW	TY IV, H/I PRISM.		5	\$ 9.15	\$ 45.75
W13-1P	24 X 24	"45 MPH"	BLACK/YELLOW	TY IV, H/I PRISM.		6	\$ 14.44	\$ 86.64
W14-1	30 X 30	"DEAD END"	BLACK/YELLOW	TY IV, H/I PRISM.		5	\$ 22.56	\$ 112.80
W14-2	30 X 30	"NO OUTLET"	BLACK/YELLOW	TY IV, H/I PRISM.	DIAMOND SHAPE	6	\$ 22.56	\$ 135.36
W14-3	48 X 48 X 36	"NO PASSING ZONE" PENNANT	BLACK/YELLOW	TY IV, H/I PRISM.	2 HOLES FOR 1 POST MOUNT	20	\$ 27.96	\$ 559.20
W16-2P	18 X 12	"500 FEET" PLAQUE	BLACK/YELLOW	TY IV, H/I PRISM.		12	\$ 5.42	\$ 65.04
W20-3	30 X 30	ROAD CLOSED	BLACK/YELLOW	TY IV, H/I PRISM.		6	\$ 22.56	\$ 135.36
N/A	30 X 30	"FLOOD AREA AHEAD"	BLACK/YELLOW	TY IV, H/I PRISM.	DIAMOND SHAPE	4	\$ 27.82	\$ 111.28

SUBTOTAL FINISHED SIGNS \$4,697.52

TOTAL COST FINISHED SIGNS \$16,167.15

Bid Submitted By: Vulcan Signs

Authorized Signature:   
David B. Beviacqua-Sales Manager

DOUGLAS COUNTY PUBLIC WORKS  
2014 COMBINED SIGN BID

3/5/2014

FLUORESCENT SIGNS

MUTCD #	SIZE	DESCRIPTION	COLOR	SHEETING	REMARKS	# TO ORDER	UNIT COST	EXTENDED COST
M4-8	24 X 12	DETOUR	FLUORESCENT ORANGE	TY VIII OR BETTER		21	\$ 15.43	\$ 324.03
M4-8a	24 X 18	END DETOUR	FLUORESCENT ORANGE	TY VIII OR BETTER		4	\$ 18.25	\$ 73.00
M4-10L	48 X 18	DETOUR ARROW - LEFT	FLUORESCENT ORANGE	TY VIII OR BETTER		2	\$ 41.12	\$ 82.24
M4-10R	48 X 18	DETOUR ARROW - RIGHT	FLUORESCENT ORANGE	TY VIII OR BETTER		2	\$ 41.12	\$ 82.24
S3-1	30 X 30	SCHOOL BUS STOP AHEAD	FLUOR. YELLOW/GREEN	TY VIII OR BETTER	FLUORESCENT YEL/GREEN	4	\$ 36.16	\$ 144.64
W1-7	60 X 30	TWO-DIRECTION LARGE ARROW	FLUORESCENT YELLOW	TY VIII OR BETTER	FLUORESCENT YELLOW	4	\$ 87.46	\$ 349.84
W8-1	36 X 36	BUMP	FLUORESCENT ORANGE	TY VIII OR BETTER		5	\$ 53.54	\$ 267.70
W8-4	36 X 36	SOFT SHOULDER	FLUORESCENT ORANGE	TY VIII OR BETTER		6	\$ 46.81	\$ 280.86
W8-8	36 X 36	ROUGH ROAD	FLUORESCENT ORANGE	TY VIII OR BETTER		1	\$ 53.54	\$ 53.54
W8-9	36 X 36	LOW SHOULDER	FLUORESCENT ORANGE	TY VIII OR BETTER		8	\$ 46.81	\$ 374.48
W8-11	36 X 36	UNEVEN LANES	FLUORESCENT ORANGE	TY VIII OR BETTER		8	\$ 46.81	\$ 374.48
W20-1	36 X 36	ROAD WORK AHEAD	FLUORESCENT ORANGE	TY VIII OR BETTER		21	\$ 46.81	\$ 983.01
W20-1	48 X 48	ROAD WORK AHEAD	FLUORESCENT ORANGE	TY VIII OR BETTER		4	\$ 91.71	\$ 366.84
W20-2	48 X 48	DETOUR AHEAD	FLUORESCENT ORANGE	TY VIII OR BETTER		6	\$ 91.71	\$ 550.26
W20-2	48 X 48	DETOUR 500 FT	FLUORESCENT ORANGE	TY VIII OR BETTER		4	\$ 103.69	\$ 414.76
W20-3	48 X 48	"ROAD CLOSED"	FLUORESCENT ORANGE	TY VIII OR BETTER	2 LINES	4	\$ 103.69	\$ 414.76
W20-3	48 X 48	ROAD CLOSED 500 FT	FLUORESCENT ORANGE	TY VIII OR BETTER		5	\$ 103.69	\$ 518.45
W20-4	36 X 36	"ONE LANE ROAD AHEAD"	FLUORESCENT ORANGE	TY VIII OR BETTER	3 LINES	14	\$ 46.81	\$ 655.34
W21-5	36 X 36	SHOULDER WORK	FLUORESCENT ORANGE	TY VIII OR BETTER		8	\$ 46.81	\$ 374.48
N/A	48 X 48	"TRUCKS TURNING"	FLUORESCENT ORANGE	TY VIII OR BETTER	2 LINES	4	\$ 103.69	\$ 414.76

TOTAL COST FLUORESCENT SIGNS \$ 7,099.71

CUT OUT LETTERING

SERIES	SIZE	DESCRIPTION	CHARACTERS	COLOR	SHEETING	REMARKS	# TO ORDER (PKG)*	UNIT COST	EXTENDED COST
SERIES D	10"	NUMBER "1"	25	BLACK	TY IV, H/I PRISM.	PRESSURE SENSITIVE	1	\$ 25.00	\$ 25.00
SERIES D	10"	NUMBER "4"	25	BLACK	TY IV, H/I PRISM.	PRESSURE SENSITIVE	1	\$ 25.00	\$ 25.00
SERIES C	8"	NUMBER "4"	25	YELLOW	TY IV, H/I PRISM.	PRESSURE SENSITIVE	1	\$ 25.00	\$ 25.00

\* NOTE: \*ASSUMING EACH PACKAGE CONTAINS 25 CHARACTERS

TOTAL COST CUT OUT LETTERING \$ 75.00

Bid Submitted By: Vulean Signs

Authorized Signature: David B. Beviacqua  
David B. Beviacqua



DOUGLAS COUNTY PUBLIC WORKS  
2014 COMBINED SIGN BID

3/5/2014

STEEL POSTS

LENGTH	WT./FT.	TYPE	REMARKS	# TO ORDER	UNIT COST	EXTENDED COST
7'	1.12#/FT.	STEEL DELINEATOR POST	GREEN ENAMEL	150	\$ 6.65	\$ 997.50
7'	3#/FT.	STEEL	GREEN ENAMEL	150	\$ 17.07	\$ 2560.50
8'	3#/FT.	STEEL	GREEN ENAMEL	60	\$ 19.51	\$ 1170.60
10'	3#/FT.	STEEL	GREEN ENAMEL	20	\$ 24.39	\$ 487.80
TOTAL COST STEEL POSTS						\$ 5,216.40

TELESPAR POSTS

LENGTH	DIMENSION	TYPE	REMARKS	REMARKS	# TO ORDER	UNIT COST	EXTENDED COST
* 10'	1-1/2" SQUARE		14 GAUGE		10	\$ 17.14	\$ 171.40
10'	1-3/4" SQUARE		14 GAUGE		100	\$ 19.20	\$ 1920.00
12'	1-3/4" SQUARE		14 GAUGE		75	\$ 23.07	\$ 1730.25
3'	2" SQUARE		12 GAUGE	TUBULAR BASE	200	\$ 8.52	\$ 1704.00
TOTAL COST TELESPAR POSTS						\$ 5,525.65	

\* 10'-1 1/2" SQ not available in 14 gauge. We bid 12 gauge.

MISCELLANEOUS ITEMS

AWARDED ON ITEM BY ITEM BASIS

SIZE	DESCRIPTION	REMARKS	# TO ORDER	UNIT COST	EXTENDED COST			
4" X 50 YD	TEMP. PVMIT MARKING TAPE, TY 2, YELLOW	FOILBACK (1 BOX @ 2 ROLLS EACH)	10	\$ NO BID	\$			
MUTCD #	SIZE	DESCRIPTION	COLOR	SHEETING	REMARKS	# TO ORDER	UNIT COST	EXTENDED COST
OM3-L	12 X 36	OM3 LEFT RE-FACE	BLACK/YELLOW	TY IV, H/I PRISM.	SHEETING ONLY - NO BLANK	10	\$ 7.97	\$ 79.70
OM3-R	12 X 36	OM3 RIGHT RE-FACE	BLACK/YELLOW	TY IV, H/I PRISM.	SHEETING ONLY - NO BLANK	10	\$ 7.97	\$ 79.70
TOTAL MISC. ITEMS						\$ 159.40		

Bid Submitted By: Vulcan Signs

Authorized Signature:

David B. Beviacqua



## DOUGLAS COUNTY PUBLIC WORKS

1242 Massachusetts Street  
Lawrence, KS 66044-3350  
(785) 832-5293 Fax (785) 841-0943  
dgcopubw@douglas-county.com  
www.douglas-county.com

**Keith A. Browning, P.E.**  
Director of Public Works/County Engineer

---

### MEMORANDUM

To : Board of County Commissioners

From : Keith A. Browning, P.E., Director of Public Works/County Engineer

Date : April 3, 2014

Re : Consider Federal Lands Access Program Project Agreement with FHWA  
Project No. 2012-14  
Route 458 improvements from E 1050 to US-59  
Polymer concrete deck overlay for Bridge No. 12.00N-11.30E

We were successful in obtaining a commitment of \$500,000 in Federal Lands Access Program (FLAP) funding from the Federal Highway Administration (FHWA) to apply towards construction of the referenced project. The FHWA requires we sign two agreements, i.e. a Project Agreement and a Reimbursable Agreement.

The Project Agreement defines roles and responsibilities of each party. In summary, the FHWA reviews environmental documentation and construction plans to ensure conformance with the stated project scope. Douglas County prepares plans, obtains necessary NEPA permits, acquires right-of-way, relocates utilities, and constructs project.

The Project Agreement also makes Douglas County responsible for all project costs in excess of \$500,000. The CIP includes \$1,600,000 for the Route 458 improvements, and \$250,000 for the deck overlay on Bridge No. 12.00N-11.30E. Please note that the Project Budget in Section F of the Project Agreement was based on very preliminary cost estimates. Our current project cost estimate is attached. FHWA's commitment of \$500,000 in FLAP funding is not affected by the lower overall project cost estimate.

We have no concerns with terms of the Project Agreement, and recommend BOCC authorize the Chair to sign the agreement.

Action Required: Approval of a Project Agreement between the Federal Highway Administration and Douglas County for Project No. 2012-14, Route 458 improvements from E 1050 to US-59 highway including a polymer concrete deck overlay for Bridge No. 12.00N-11.30E.

Date: 3/7/2014  
By: KAB

PROJECT COST ESTIMATE  
Route 458 from Banning's Corner to US-59\*  
Proj. No. 2012-14

Construction*	\$ 1,635,948
Contingencies (10%)	\$ 163,595
Total Estimated Construction Cost	\$ 1,799,543
FLAP funding**	\$ 500,000

DGCO Costs:

Construction	\$ 1,299,543
Engrg. Design	\$ -
Right-of-Way	\$ 50,000
Waterline Relocation	\$ 12,993
Phone Line Relocation (SBC)	\$ 128,831
Power Line Relocation (Westar)***	\$ -
Materials Testing	\$ 4,000

Total DGCO Costs **\$ 1,495,367**

\*Includes polymer concrete overlay for Bridge No. 1200-1130

\*\*Federal Lands Access Program (FLAP)

\*\*\*Power poles in existing R/W

**FEDERAL LANDS ACCESS PROGRAM**  
**PROJECT MEMORANDUM OF AGREEMENT**

**Project / Facility Name: CR458 / RS207 (N 1200 Rd)**

**Project Route: CR 458**

**State: Kansas**

**County: Douglas**

**Owner of Federal Lands to which the Project Provides Access: Army Corps of Engineers**

**Entity with Title or Maintenance Responsibility for Facility: Douglas County Kansas**

**Type of Work:** This Light 4R project provides access to all the recreational areas at Clinton Lake and to the city operated golf course located on the Corps of Engineers' property below the dam. The road exhibits rutting, alligator cracking, transverse and longitudinal cracking, and edge cracking. This road needs major maintenance to provide safe conditions for all bicyclists and drivers, including drivers pulling boats to the lake.

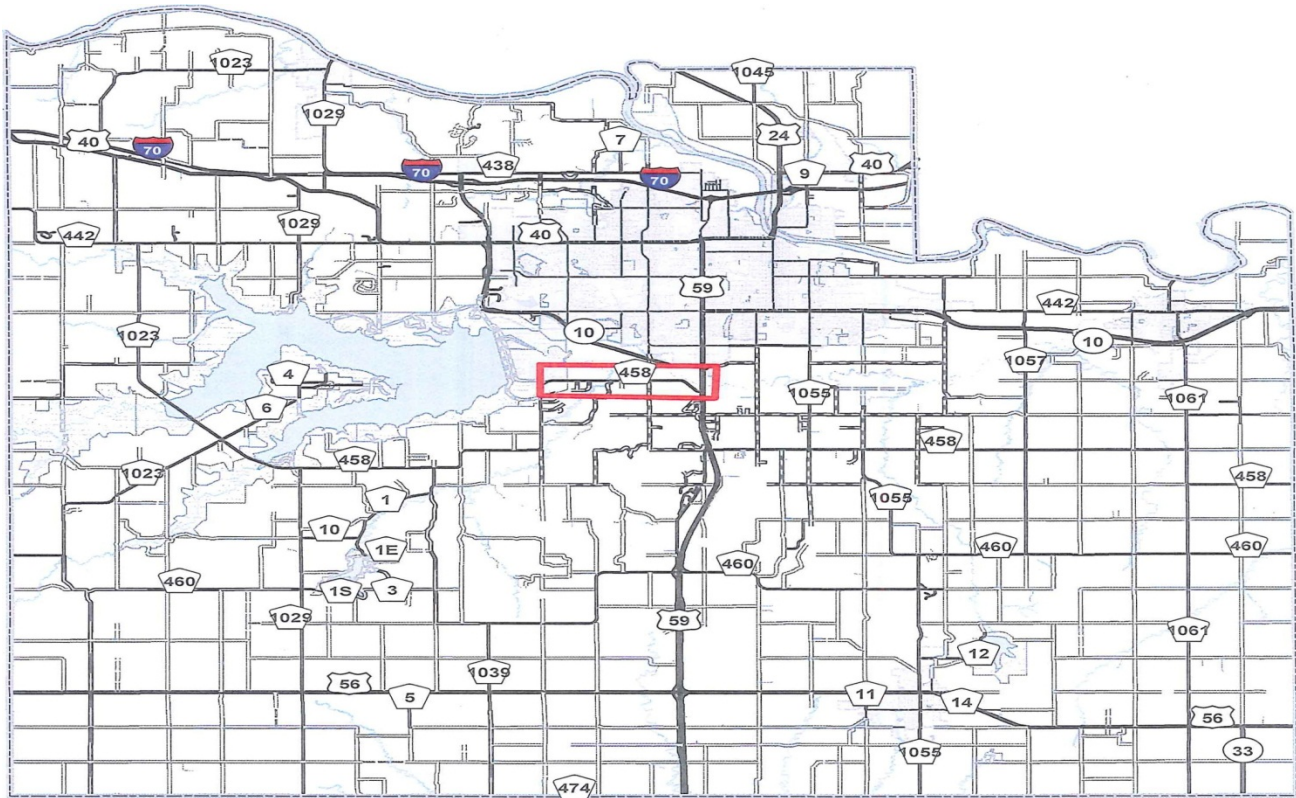

- CR458 has significant bicycle traffic and bicyclists are forced to ride in the travel lane on this 55 mph road due to the lack of paved shoulders, placing them at high risk.
- Wetlands Bank Mitigation described in the application is not necessary per the US Army Corps of Engineers NWP#14 letter. The ditch design and seed choice will mitigate.

Reconstruct existing 24 foot road to 24 feet with 6.5 foot paved shoulders. Patch and overlay existing 24 feet. Construct paved shoulders for use by bicycles. In western portion of project, roadside ditch will be filled and underground storm sewer installed. For remainder of project, flat bottom ditches will be constructed on both sides of the road with flatter foreslopes and backslopes. Rehabilitate the existing pavement by milling, full depth asphalt patching, and 3" overlay. Construct 6.5 feet wide asphalt shoulders to improve roadway safety as well as providing an area for bicycles to ride safely. Construct flat bottom ditches along each side of the road, extend or replace culverts to provide adequate clear zone, and flatten foreslopes and backslopes to meet current safety standards.

Douglas County engineers have prepared preliminary construction plans. Douglas County currently has the remaining funds needed for this project budgeted in the Capital Improvement Program (CIP) for construction in 2014. As a certified LPA county by the Kansas Department of Transportation, Douglas County will provide all Construction Engineering in conjunction with CFL Oversight.

This Agreement does not obligate or commit to the expenditure of Federal funds nor does it commit the parties to complete the project. Rather, this Agreement sets forth the respective responsibilities for managing of permits, utilities, Right-of-Way, and NEPA impacts as the project proceeds through the project development and construction process.

**Parties to this Agreement:**

Douglas County Kansas

Federal Highway Administration Central Federal Lands Highway Division (CFLHD)

The Program Decision Committee approved this project on August 15<sup>th</sup> 2013.

**AGREED:**

---

Nancy Thellman, Date  
 Chair, Board of County Commissioners  
 Douglas County, Kansas

---

Michael Davies Date  
 Director, Office of Project Delivery  
 FHWA- CFLHD

**A. PURPOSE OF THIS AGREEMENT**

This Agreement documents the intent of the parties and sets forth the anticipated responsibilities of each party in the development, construction, and future maintenance of the subject project. The purpose of the Agreement is to identify and assign responsibilities for the environmental analysis, design, right-of-way, utilities, acquisition and construction as appropriate for this programmed project, and to ensure maintenance of the facility for public use if improvements are made. The parties understand that any final decision as to design or construction will not be made until after the environmental analysis required under the National Environmental Policy Act (NEPA) is completed (this does not prevent the parties from assigning proposed design criteria to be studied in the NEPA process.) Any decision to proceed with the design and construction of the project will depend on the availability of appropriations at the time of obligation and other factors such as issues raised during the NEPA process, a natural disaster that changes the need for the project, a change in Congressional direction, or other relevant factors.

If Federal Lands Access Program funds are used for the development or construction of this project, the Douglas County Board of County Commissioners agrees to provide a matching share equal to all costs greater than \$500,000 of the total cost of the project, as detailed more fully in Section J below.

**B. AUTHORITY**

This Agreement is entered into between the signatory parties pursuant to the provisions of 23 U.S.C. 204.

**C. JURISDICTION AND MAINTENANCE COMMITMENT**

Douglas County Kansas has jurisdictional authority to operate and maintain the existing facility and will operate and maintain the completed project at its expense.

**D. FEDERAL LAND MANAGEMENT AGENCY COORDINATION**

The Douglas County Public Works Department has coordinated project development with the US Army Corps of Engineers, KC District. The US Army Corps of Engineers, KC District support of the project is documented by their digital signature and support acknowledgement in the KS FLAP application and their letter authorizing the project under NWP #14 dated August 12<sup>th</sup> 2013. Each party to this agreement who has a primary role in NEPA, design, or construction shall coordinate their activities with the US Army Corps of Engineers, KC District.

**E. PROJECT BACKGROUND/SCOPE**

Route 458 from US-59 west to Clinton Lake is the primary access road to all the recreational areas at Clinton Lake. It also provides access to the city operated golf course located on the Corps of Engineers' property below the Clinton Lake Dam. All these recreational facilities served 1,355,970 visitors in 2012. This road also has significant bicycle traffic.

- There have been 46 total accidents on this portion of Route 458 in the past 10 years. Of these total accidents, 14 have been injury accidents, 13 have been property damage only, and 19 have been accidents involving deer.
- Lack of shoulders and inadequate clear zones are a safety concern for all road users.

The road currently has an ADT of 2064vpd and a PCI of 65 that exhibits extensive rutting, alligator cracking, transverse, longitudinal and edge cracking. Due to the lack of paved shoulders, bicyclists are forced to ride in the travel lane of this 55 mph road which causes safety concerns for both the bicyclist and vehicle drivers.

Route 458 will be reconstructed beginning approximately 450 feet west of US-59 and then extend west 2.5 miles which reaches the Corps property below the Clinton Lake Dam. The project will include a multi-layer polymer concrete overlay repair to the bridge located approximately 1.7 miles west of US-59 and rehabilitate the existing pavement by milling, full depth patching, and a 3” overlay.

The improvements also include the construction of flat bottom ditches along each side of the road, and the construction of 6.5 feet wide paved shoulders which provides roadside safety for vehicles and also provides additional pavement width for bicyclists to ride safely. The project also includes some underground storm sewer in the residential area, replacing culverts to provide adequate clear zone, and flattening foreslopes and backslopes to meet current safety standards.

If the utility is located within the existing right-of-way, the utility will relocate at their expense. Utilities have been notified of this project and have been provided preliminary plans. Using local CIP funding, Douglas County will reimburse utilities for all relocations where the utility is currently located in a private easement and provide DOT Form 1306 prior to construction.

18 tracts are required, all landowners have been contacted, no condemnation anticipated. Douglas County personnel are knowledgeable of federal ROW acquisition procedures, and will acquire additional right-of-way as needed to construct these improvements. Funding will be provided by the Douglas County Capital Improvement Plan (CIP). Once started, this acquisition process is estimated to be completed by April 15, 2014.

NPDES, NWP, SHPO and KS Department of Wildlife, Parks and Tourism Permits have already been obtained by Douglas County Public Works.

This road needs significant improvements both to improve the rideability of the road surface for vehicles and to provide a safer road width and surface for bicyclists.

Based on the FHWA Crash Reduction Factors, adding or widening paved shoulders from 0 to 6 feet reduces crashes by 40%.

**F. PROJECT BUDGET**

<b>Item</b>	<b>Estimate (\$)</b>	<b>Comments</b>
ROW	100,000	
Scoping, mid and final	1,000	All PE is completed
Utilities	200,000	
NEPA Permits	20,000	DCPW provide NEPA Clearance Doc
Preliminary Eng. & Design	0	Performed by Douglas County
Construction	2,250,000	
Construction Eng.	0	Performed by Douglas County

Item	Estimate (\$)	Comments
<b>SUBTOTAL</b>	2,571,000	
Project Contingency 10%	0	Included in County CN EE
Total	\$ 2,571,000	

**G. ROLES AND RESPONSIBILITIES**

Responsible Party	Product/Service/Role	Comments
FHWA-CFLHD	<ul style="list-style-type: none"> <li>• Develop and sign this Project Agreement</li> <li>• Review the environmental documents, plans and specifications at each phase of design and provide project development support</li> <li>• In coordination with the FHWA-CFLHD project manager, ensure that completed plans, specifications, and estimates (PS&amp;E) are consistent with the intended outcome</li> <li>• Provide overall direction regarding policy and administration for the project and concur with the final plans and specifications</li> <li>• Coordinate with Douglas County on NEPA related issues</li> <li>• Communicate with PM who will be the primary contact for FHWA-CFLHD's during construction</li> </ul> <p>Attend a final inspection with Douglas County and US Army Corps of Engineers upon completion of construction</p>	



Responsible Party	Product/Service/Role	Comments
Douglas County	<ul style="list-style-type: none"> <li>• Review and sign this Project Agreement</li> <li>• Prior to ROW acquisition provide NEPA documentation.</li> <li>• Provide in a timely manner available data including but not limited to traffic, accidents, material sources, construction costs, agreements, other technical data</li> <li>• Prepare and submit to FHWA-CFLHD the environmental documents, plans and specifications at each phase of design and provide project development support</li> <li>• In coordination with the FHWA-CFLHD project manager, ensure that completed plans, specifications, and estimates (PS&amp;E) are consistent with the intended outcome</li> <li>• Prior to construction provide ROW and utility certification and coordination</li> <li>• Provide utility status</li> <li>• Sign KDOT Utility and Right of Way certifications</li> <li>• Coordinate with FHWA-CFLHD on NEPA related issues</li> <li>• If required, enter into a formal partnering work session and agreement with all parties involved in the construction contract.</li> <li>• Designate a representative who will be the primary contact for FHWA-CFLHD's Project Manager during construction</li> <li>• Attend a final inspection with the FHWA-CFLHD and US Army Corps of Engineers upon completion of construction</li> <li>• Obtain all permits prior to construction</li> </ul>	

**H. ROLES AND RESPONSIBILITIES – SCHEDULE**

<b>Responsible Lead</b>	<b>Product/Service/Role</b>	<b>Schedule Finish Date</b>	<b>Comments</b>
FHWA-CFLHD	Project Agreement and Reimbursable Agreement	March 31 2014	
DCPW	Environmental Compliance	May 2014	Biological Assessment Completed
DCPW	Design	Completed	Develop 100% PS&E
DCPW	ROW Acquisition	April 2014	
DCPW	Advertise and Award Contract and NTP	May 2014	Dependent on FLAP funding and County Match in place

**I. PROPOSED DESIGN STANDARDS:**

Final design standards will be determined through the NEPA process.

<b>Criteria</b>		<b>Comments</b>
Standard	AASHTO 2004	Green Book
Functional Classification	Arterial, Rural	
Surface Type	HMA	
Design Volume	2500 vpd	

**J. FUNDING**

<b>Fund Source</b>	<b>Amount</b>	<b>Comments</b>
Kansas Federal Lands Access Program Funds	\$500,00	
Local Matching Share-Douglas County, Kansas	\$2,071,00	80.54%
<b>TOTAL</b>	<b>\$2,571,000</b>	

**K. MATCHING SHARE REQUIREMENTS**

Matching or cost sharing requirements may be satisfied following the obligation of funds to the project by: allowable costs incurred by the State or local government, cash donations, the fair and reasonable value of third party in-kind contributions (but only to the extent that the value of the costs would be allowable if paid for by the party responsible for meeting the matching share), including materials or services; however no costs or value of third party contributions may count towards satisfying the matching share requirements under this agreement if they have or will be counted towards meeting the matching share requirements under another federal award.

Costs and third party contributions counting toward satisfying a cost sharing or matching requirement must be verifiable from the records of the party responsible for meeting the matching requirements. The records must demonstrate how the value of third party in kind contributions was derived. Voluntary services sought to be applied to the matching share will be supported by the same methods that the party to this agreement uses to support allocability of personnel costs. Any donated services provided by a third party will be valued at rates consistent with those ordinarily paid by employers for similar work in the same labor market. Supplies furnished will be valued at their market value at the time of donation. Donated equipment or space will be valued at fair rental rate of the equipment or space. All records associated with valuations or costs under section K shall be accessible and be maintained for three years following project close-out.

**L. PROJECT TEAM MEMBERS - POINTS OF CONTACT**

The following table provides the points of contact for this project. They are to be the first persons to deal with any issues or questions that arise over the implementation of each party’s role and responsibility for this agreement.

<b>Name/Title</b>	<b>Organization</b>	<b>Address/Phone Number/Email</b>
Terese Gorman Engineer Div Mgr	Douglas County Public Works	<a href="mailto:tgorman@douglas-county.com">tgorman@douglas-county.com</a> 785.841.5332
Susanna Gehrt Operations Project Manger	US Army Corps of Engineer. KC District	<a href="mailto:Susanna.G.Gehrt@usace.army.mil">Susanna.G.Gehrt@usace.army.mil</a> 816.389.3635
Allen Grasmick KS FLAP Program Manager	FHWA Division	<a href="mailto:Allen.grasmick@dot.gov">Allen.grasmick@dot.gov</a> 720-963-3664

**M. CHANGES/AMENDMENTS/ADDENDUMS**

The agreement may be modified, amended, or have addendums added by mutual agreement of all parties. The change, amendment, or addendum must be in writing and executed by all parties.

The types of changes envisioned include, but are not limited to, changes that significantly impact scope, schedule, or budget; changes to the local match, either in type or responsibility; changes that alter the level of effort or responsibilities of a party. The parties commit to consider suggested changes in good faith. Failure to reach agreement on changes may be cause for termination of this agreement.

A change in the composition of the project team members does not require the agreement to be amended. It is the responsibility of the project team members to recognize when changes are needed and to make timely notification to their management in order to avoid project delivery delays.

**N. ISSUE RESOLUTION PROCEDURES MATRIX**

Issues should be resolved at the lowest level possible. The issue should be clearly defined in writing and understood by all parties. Escalating to the next level can be requested by any party. When an issue is resolved, the decision will be communicated to all levels below.

<b>FHWA-CFLHD</b>	<b>Douglas County, KS</b>	<b>Time</b>
Jeff Jerome Project Manager	Terese Gorman Engineering Division Manager	14 days
Gary Strike Project Manager Branch Chief	Keith Browning Director of Public Works/County Engineer	30 days
Michael Davies Director, Office of Project Delivery	Craig Weinaug Douglas County Administrator	90 days

**O. TERMINATION**

This agreement may be terminated by mutual written consent of all parties. This agreement may also be terminated if either the NEPA process or funding availability requires a change and the parties are not able to agree to the change. Any termination of this agreement shall not prejudice any rights or obligations accrued to the parties prior to termination. If Federal Access funds have been expended prior to termination, the party responsible for the match agrees to provide a match in the applicable percentage of the total amount expended on the project prior to the termination.

**P. STEWARDHIP & OVERSIGHT ACTIVITIES**

<b>Item –Planning &amp; Programming</b>	<b>Douglas County</b>	<b>CFLHD</b>
Evidence that project is on an approved program of projects	Provide	Review
Evidence of being on a TIP or STIP	Provide	Review
Project agreement with scope, schedule, & budget	Provide Form 1307 (list of permits and status)	Concur
<b>Item Environment</b>	<b>Douglas County</b>	<b>CFLHD</b>
Anticipated NEPA action	Provide	Review
Copy of Draft documents	Provide General Condition 30 Compliance Certificate	Review & Concur
Sign off on FHWA NEPA document	Provide	Concur
Copy of NEPA action	Provide	File
Evidence of permits	Provide Exemption Certificates	File
<b>Item Designs</b>	<b>Douglas County</b>	<b>CFLHD</b>
Review 70% PS&E	Provide	Review
Review or approve design exceptions	Provide	Review
Utility Agreements	Provide DOT Form 1304 (list of utilities and status)	File
<b>Item Acquisitions</b>	<b>Douglas County</b>	<b>CFLHD</b>
Review contract package for required clauses	Provide	Review
Concur in award of contract	Provide	Concur
Review ROW certifications	Provide DOT Form 1306 (ROW clearance form)	File

<b>Item –Planning &amp; Programming</b>	<b>Douglas County</b>	<b>CFLHD</b>
Receive copy of award package	Provide	File
Review or approve contract modifications	Provide	Review & Concur
<b>Item Construction</b>	<b>Douglas County</b>	<b>CFLHD</b>
Attend Project Inspections: Mid-construction; Final (minimum)	Schedule	Attend



## DOUGLAS COUNTY PUBLIC WORKS

1242 Massachusetts Street  
Lawrence, KS 66044-3350  
(785) 832-5293 Fax (785) 841-0943  
dgcopubw@douglas-county.com  
www.douglas-county.com

**Keith A. Browning, P.E.**  
Director of Public Works/County Engineer

---

### MEMORANDUM

To : Board of County Commissioners

From : Keith A. Browning, P.E., Director of Public Works/County Engineer

Date : April 1, 2014

Re : Authorization to solicit construction bids for Project No. 2012-14  
Route 458 improvements from E 1050 to US-59  
Polymer concrete deck overlay for Bridge No. 12.00N-11.30E

The referenced project includes pavement rehabilitation and construction of 6.5'-wide paved shoulders on approximately 2.5 miles of Route 458 from the east end of the Banning's Corner curve at approximately E 1050 to US-59 highway. Roadside safety will be improved by the construction of paved shoulders, flatter ditch frontslopes and backslopes, and replacement of narrow culverts. The project also includes a polymer concrete overlay for bridge number 12.00N-11.30E, which carries Route 458 over Washington Creek. A project cost estimate is attached.

The CIP includes \$1,600,000 for the Route 458 improvements, and \$250,000 for the deck overlay on Bridge No. 12.00N-11.30E, both of which are scheduled for 2014 construction. We were also successful in obtaining \$500,000 in Federal Lands Access Program (FLAP) funding from the FHWA for the Route 458 improvements. The FHWA is preparing a project agreement for BoCC consideration. At the time of this writing, we do not yet have the final agreement form. However, we have seen drafts of the agreement and have no concerns over its terms.

Plans have been developed in-house. Acquisition of necessary additional easements and right-of-way is nearly complete. Relocation of utilities will require approximately 30 days after all additional right-of-way is acquired. We plan to open bids in late-April with construction commencing in late-May. We estimate construction will be complete by October 1.

Following the opening of bids, a construction contract will be presented to the BoCC for consideration of approval.

Action Required: Authorization to solicit bids for Project No. 2012-14, Route 458 improvements from E 1050 to US-59 highway including a polymer concrete deck overlay for Bridge No. 12.00N-11.30E.

Date: 3/7/2014  
By: KAB

PROJECT COST ESTIMATE  
Route 458 from Banning's Corner to US-59\*  
Proj. No. 2012-14

Construction*	\$ 1,635,948
Contingencies (10%)	\$ 163,595
Total Estimated Construction Cost	\$ 1,799,543
FLAP funding**	\$ 500,000

DGCO Costs:

Construction	\$ 1,299,543
Engrg. Design	\$ -
Right-of-Way	\$ 50,000
Waterline Relocation	\$ 12,993
Phone Line Relocation (SBC)	\$ 128,831
Power Line Relocation (Westar)***	\$ -
Materials Testing	\$ 4,000

Total DGCO Costs **\$ 1,495,367**

\*Includes polymer concrete overlay for Bridge No. 1200-1130

\*\*Federal Lands Access Program (FLAP)

\*\*\*Power poles in existing R/W



## DOUGLAS COUNTY PUBLIC WORKS

1242 Massachusetts Street  
Lawrence, KS 66044-3350  
(785) 832-5293 Fax (785) 841-0943  
dgcopubw@douglas-county.com  
www.douglas-county.com

**Keith A. Browning, P.E.**  
Director of Public Works/County Engineer

---

### MEMORANDUM

To : Board of County Commissioners

From : Keith A. Browning, P.E., Director of Public Works/County Engineer

Date : April 2, 2014

Re : Consider contract with KDHE to clean-up illegal dump site

The Kansas Department of Health & Environment (KDHE) has a program under which they contract with local units of government to clean up illegal dump sites. KDHE pays for 75% of the clean-up costs, and the local government is responsible for 25% of the costs, towards a maximum \$10,000 project limit. The local government's cost share can be paid by supplying in-kind contributions of labor and equipment costs to clean up the illegal dump site.

Bob Medina, KDHE Environmental Scientist, notified the DGCO Zoning & Codes Department of an illegal dump within public road right-of-way along E 2000 Road beneath the K-10 bridges over the Wakarusa River. Personnel from Zoning & Codes and Public Works visited the site along with KDOT personnel and Bob Medina.

It is proposed to use Public Works personnel and equipment to perform the clean-up work. KDHE's illegal dump clean-up program does not allow them to contract with KDOT or other state agencies, however KDOT offered to provide a piece of equipment and operator, if needed. We anticipate the work can be performed in one day by county forces, and costs will be within the \$10,000 project limit. We do not anticipate any unreimbursed out-of-pocket costs to Douglas County.

We plan to clean up the illegal dump as soon as possible and prior to significant spring vegetation growth. If it is not done very soon, we may want to wait until late next fall to clean it up. The illegal dump area is significantly overgrown with vines that will make clean-up more difficult once the growing season is fully underway.

Attached is a contract between KDHE and Douglas County for the clean-up work. The BoCC chair should sign two original copies of the attached contract.

Action Required: Approval for the BoCC Chair to sign two original copies of the attached contract with KDHE concerning cost reimbursement for cleaning up an illegal dump along E 2000 Road beneath K-10 highway.



## CONTRACT

Between

THE KANSAS DEPARTMENT OF HEALTH AND ENVIRONMENT  
And  
DOUGLAS COUNTY

SUBJECT: Corrective action at Illegal Dump Site #1

DIVISION: Bureau of Waste Management

### CONTRACT

PERIOD: March 25, 2014 to June 16, 2014

AMOUNT: Estimated \$5,500.00 not to exceed \$10,000.00

This agreement between the Kansas Department of Health and Environment (hereinafter KDHE) and Douglas County takes effect upon signature of the Secretary of the Kansas Department of Health and Environment.

A portion of public road right-of-way in the East ½ of Northeast ¼ of Southeast ¼ of Section 12, Township 13 South, Range 20 East located in Douglas County, Kansas is an illegal solid waste dumping area pursuant to K.S.A. 65-3415(a). Unknown Members used this area as an illegal solid waste dumping site. The referenced portion of road right-of-way is owned by the State of Kansas, and E 2000 Road is currently maintained by Eudora Township on behalf of Douglas County. Douglas County has agreed to administer the contract.

K.S.A. 65-3415a(c)(12) authorizes the secretary of KDHE to pay for seventy-five percent (75%) up to a maximum of ten thousand dollars (\$10,000) of the costs of removal and disposal or stabilization of solid waste from the site of illegal dumping activity, if the city or county of jurisdiction consents.

K.S.A. 65-3415a(d) requires that the person(s) responsible for the illegal solid waste dumping activity at the subject site, whose failure to comply with the solid waste act, rules and regulations or permit conditions resulted in the determination that expenditures from the solid waste fund are necessary, are responsible for repayment of those funds. The secretary shall, in his discretion, take the appropriate action to recover those funds.

The secretary has determined that the above site is an illegal solid waste dumping site which requires authorized corrective action, and also that the person(s) responsible for the illegal dumping activity is/are either unknown, unable or unwilling to pay for the cost of corrective action.

Douglas County wishes to enter into an agreement to perform corrective action at the above illegal solid waste dumping site.

The secretary has determined that it is most cost effective for Douglas County to perform or contract for performance of the tasks necessary to take correction action at the site.

In consideration of the foregoing and the representations and obligations undertaken herein and intending to be legally bound, the parties hereto agree as follows:

I. The KDHE shall:

- (1) Provide reimbursement to Douglas County for 75% of their actual cost of corrective action not to exceed \$10,000.
- (2) Agree that Douglas County may utilize the labor cost of its employees and cost of use of appropriate equipment in the calculation of its total cost of corrective action, subject to review and approval by KDHE.
- (3) Advance 25% of \$10,000.00 or \$2,500.00.00 of the estimated contract amount upon execution of the contract.
- (4) Reimburse the remainder of the actual cost contract amount upon completion of the project as verified by receipt of Certified Expenditure Affidavits supported by evidence of expenditure, if KDHE approves the evidence of expenditure as appropriate. No reimbursements will be processed until the advanced contract amount is expended.
- (5) Review all requests and contracts submitted by Douglas County for approval by KDHE within thirty days of receipt by KDHE.
- (6) Provide technical assistance to Douglas County for project execution and administration.

II. Douglas County:

- (1) Shall incur 25% of the total cost of the clean up, either through the direct payment of expenses or supplying a minimum of in-kind contributions through labor, equipment or landfill space.
- (2) Shall submit a work plan to KDHE for approval prior to initial distribution of funds.

(3) Shall submit Certified Expenditure Affidavits and a final affidavit supported by evidence of expenditures upon completion of the project and a final affidavit. The final affidavit shall be received by KDHE no later than 30 days after completion of the project. Complete, accurate documentation and current accounting of all funds received and expended shall be maintained to provide an audit trail to source documentation.

(4) Agrees that no capital equipment will be purchased with the funds provided by KDHE. No matching funds will be reimbursed to Douglas County for the purchase of any capital equipment.

(5) Submit all contracts over \$500 for approval by KDHE. KDHE recommends that Douglas County use competitive bid procedures for purchases over \$500, however, Douglas County may follow the same policies and procedures utilized for procurements obtained in the normal course of business.

(6) Afford access, upon written request, to the secretary of KDHE or the secretary's authorized representative, or Kansas Legislative Post Audit to any documents and other records necessary to certify compliance with Kansas statutes, regulations, and appropriation requirements.

(7) Complete the project as specified in the approved work plan.

(8) Submit a final report to KDHE detailing the work accomplished in implementing the work plan.

(9) Obtain all necessary site access agreements. Documentation of any such agreements shall be submitted to KDHE with the final report or upon request of KDHE.

(10) Provide additional funds or resources, over the contract amount, as necessary, for completion of the project.

III. The parties mutually agree that:

(1) Failure to submit an acceptable work plan shall render this contract void.

(2) The provisions found in Contractual Provisions Attachment (Form DA-146a), which is attached hereto and executed by the parties to the agreement, are hereby incorporated into this contract and are made a part hereof.

(3) This agreement constitutes the whole agreement between the parties, and it is mutually understood and agreed that no alternative or variation to the terms of this agreement shall be valid unless amendments hereto are made in writing and agreed to by both parties.

(4) This contract shall terminate upon Douglas County receipt of written notice from KDHE that the Douglas County has demonstrated that the items set forth in the work plan were satisfactorily completed.

(5) Nothing in this agreement shall be considered an admission of any fact or an acknowledgment of any liability; and, nothing herein shall be binding or have any effect on the position of the parties on any other agreements which may be negotiated between them.

(6) KDHE and Douglas County will not be liable for any acts or omissions of their respective employees, agents, assigns, contractors, or persons acting on behalf of KDHE or Douglas County in carrying out any activities pursuant to the terms of this agreement, beyond that liability granted by the Kansas Tort Claims Act, K.S.A. 75-6101 *et seq.*

(7) Failure to obtain necessary site access agreements, per paragraph II.(9), and/or to submit documentation of access agreements to KDHE upon KDHE's request, shall result in KDHE denying reimbursement of outstanding funds to Douglas County.

(8) KDHE shall not be responsible for any payments for site access or crop damage.

(9) By signing this agreement, the person below warrants that he or she has the authority to sign this document and to bind the parties to its terms.

IN WITNESS WHEREOF, the parties hereto have affixed their signatures on the dates indicated below.

\_\_\_\_\_  
Nancy Thellman, Chair  
Board of County Commissioners  
Douglas County, Kansas

Date: \_\_\_\_\_

\_\_\_\_\_  
Robert Moser, MD, Secretary  
Kansas Department of Health  
and Environment

\_\_\_\_\_  
Date

CONTRACTUAL PROVISIONS ATTACHMENT

Important: This form contains mandatory contract provisions and must be attached to or incorporated in all copies of any contractual agreement. If it is attached to the vendor/contractor's standard contract form, then that form must be altered to contain the following provision:

"The Provisions found in Contractual Provisions Attachment (Form DA-146a, Rev. 06-12), which is attached hereto, are hereby incorporated in this contract and made a part thereof."

The parties agree that the following provisions are hereby incorporated into the contract to which it is attached and made a part thereof, said contract being the \_\_\_\_\_ day of \_\_\_\_\_, 20\_\_\_\_\_.

- Terms Herein Controlling Provisions:** It is expressly agreed that the terms of each and every provision in this attachment shall prevail and control over the terms of any other conflicting provision in any other document relating to and a part of the contract in which this attachment is incorporated. Any terms that conflict or could be interpreted to conflict with this attachment are nullified.
- Kansas Law and Venue:** This contract shall be subject to, governed by, and construed according to the laws of the State of Kansas, and jurisdiction and venue of any suit in connection with this contract shall reside only in courts located in the State of Kansas.
- Termination Due To Lack Of Funding Appropriation:** If, in the judgment of the Director of Accounts and Reports, Department of Administration, sufficient funds are not appropriated to continue the function performed in this agreement and for the payment of the charges hereunder, State may terminate this agreement at the end of its current fiscal year. State agrees to give written notice of termination to contractor at least 30 days prior to the end of its current fiscal year, and shall give such notice for a greater period prior to the end of such fiscal year as may be provided in this contract, except that such notice shall not be required prior to 90 days before the end of such fiscal year. Contractor shall have the right, at the end of such fiscal year, to take possession of any equipment provided State under the contract. State will pay to the contractor all regular contractual payments incurred through the end of such fiscal year, plus contractual charges incidental to the return of any such equipment. Upon termination of the agreement by State, title to any such equipment shall revert to contractor at the end of the State's current fiscal year. The termination of the contract pursuant to this paragraph shall not cause any penalty to be charged to the agency or the contractor.
- Disclaimer Of Liability:** No provision of this contract will be given effect that attempts to require the State of Kansas or its agencies to defend, hold harmless, or indemnify any contractor or third party for any acts or omissions. The liability of the State of Kansas is defined under the Kansas Tort Claims Act (K.S.A. 75-6101 et seq.).
- Anti-Discrimination Clause:** The contractor agrees: (a) to comply with the Kansas Act Against Discrimination (K.S.A. 44-1001 et seq.) and the Kansas Age Discrimination in Employment Act (K.S.A. 44-1111 et seq.) and the applicable provisions of the Americans With Disabilities Act (42 U.S.C. 12101 et seq.) (ADA) and to not discriminate against any person because of race, religion, color, sex, disability, national origin or ancestry, or age in the admission or access to, or treatment or employment in, its programs or activities; (b) to include in all solicitations or advertisements for employees, the phrase "equal opportunity employer"; (c) to comply with the reporting requirements set out at K.S.A. 44-1031 and K.S.A. 44-1116; (d) to include those provisions in every subcontract or purchase order so that they are binding upon such subcontractor or vendor; (e) that a failure to comply with the reporting requirements of (c) above or if the contractor is found guilty of any violation of such acts by the Kansas Human Rights Commission, such violation shall constitute a breach of contract and the contract may be cancelled, terminated or suspended, in whole or in part, by the contracting state agency or the Kansas Department of Administration; (f) if it is determined that the contractor has violated applicable provisions of ADA, such violation shall constitute a breach of contract and the contract may be cancelled, terminated or suspended, in whole or in part, by the contracting state agency or the Kansas Department of Administration.

Contractor agrees to comply with all applicable state and federal anti-discrimination laws.

The provisions of this paragraph number 5 (with the exception of those provisions relating to the ADA) are not applicable to a contractor who employs fewer than four employees during the term of such contract or whose contracts with the contracting State agency cumulatively total \$5,000 or less during the fiscal year of such agency.

- Acceptance Of Contract:** This contract shall not be considered accepted, approved or otherwise effective until the statutorily required approvals and certifications have been given.
- Arbitration, Damages, Warranties:** Notwithstanding any language to the contrary, no interpretation of this contract shall find that the State or its agencies have agreed to binding arbitration, or the payment of damages or penalties. Further, the State of Kansas and its agencies do not agree to pay attorney fees, costs, or late payment charges beyond those available under the Kansas Prompt Payment Act (K.S.A. 75-6403), and no provision will be given effect that attempts to exclude, modify, disclaim or otherwise attempt to limit any damages available to the State of Kansas or its agencies at law, including but not limited to the implied warranties of merchantability and fitness for a particular purpose.
- Representative's Authority To Contract:** By signing this contract, the representative of the contractor thereby represents that such person is duly authorized by the contractor to execute this contract on behalf of the contractor and that the contractor agrees to be bound by the provisions thereof.
- Responsibility For Taxes:** The State of Kansas and its agencies shall not be responsible for, nor indemnify a contractor for, any federal, state or local taxes which may be imposed or levied upon the subject matter of this contract.
- Insurance:** The State of Kansas and its agencies shall not be required to purchase any insurance against loss or damage to property or any other subject matter relating to this contract, nor shall this contract require them to establish a "self-insurance" fund to protect against any such loss or damage. Subject to the provisions of the Kansas Tort Claims Act (K.S.A. 75-6101 et seq.), the contractor shall bear the risk of any loss or damage to any property in which the contractor holds title.
- Information:** No provision of this contract shall be construed as limiting the Legislative Division of Post Audit from having access to information pursuant to K.S.A. 46-1101 et seq.
- The Eleventh Amendment:** "The Eleventh Amendment is an inherent and incumbent protection with the State of Kansas and need not be reserved, but prudence requires the State to reiterate that nothing related to this contract shall be deemed a waiver of the Eleventh Amendment."
- Campaign Contributions / Lobbying:** Funds provided through a grant award or contract shall not be given or received in exchange for the making of a campaign contribution. No part of the funds provided through this contract shall be used to influence or attempt to influence an officer or employee of any State of Kansas agency or a member of the Legislature regarding any pending legislation or the awarding, extension, continuation, renewal, amendment or modification of any government contract, grant, loan, or cooperative agreement.



## DOUGLAS COUNTY PUBLIC WORKS

1242 Massachusetts Street  
Lawrence, KS 66044-3350  
(785) 832-5293 Fax (785) 841-0943  
dgcopubw@douglas-county.com  
www.douglas-county.com

**Keith A. Browning, P.E.**  
Director of Public Works/County Engineer

---

### MEMORANDUM

TO : Douglas County Commission

FROM: Keith A. Browning, P.E., Director of Public Works/County Engineer  
Michael D. Kelly, P.S., County Surveyor

DATE : April 1, 2014

RE : Placement of gate on E2000 Road

We have identified a need to install a gate across E2000 Road in Eudora Township near K-10 Highway. The location proposed is close to the K-10 bridges over the Wakarusa River. See the attached map.

The Public Works Department has been working with the Kansas Department of Health and Environment (KDHE) in an effort to eliminate illegal dumping in this location and it has been determined a gate limiting access to the site may be the most promising alternative at this point in time.

A resolution has been prepared which will authorize the installation of a gate at the desired location.

**ACTION REQUIRED:** A motion is required to authorize the Board to affix their signatures to the attached resolution.

# Proposed Gate

## General Location Map

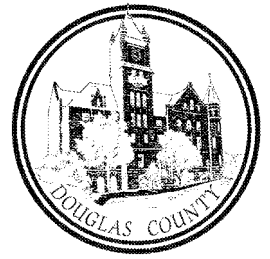

1 inch = 1,500 feet

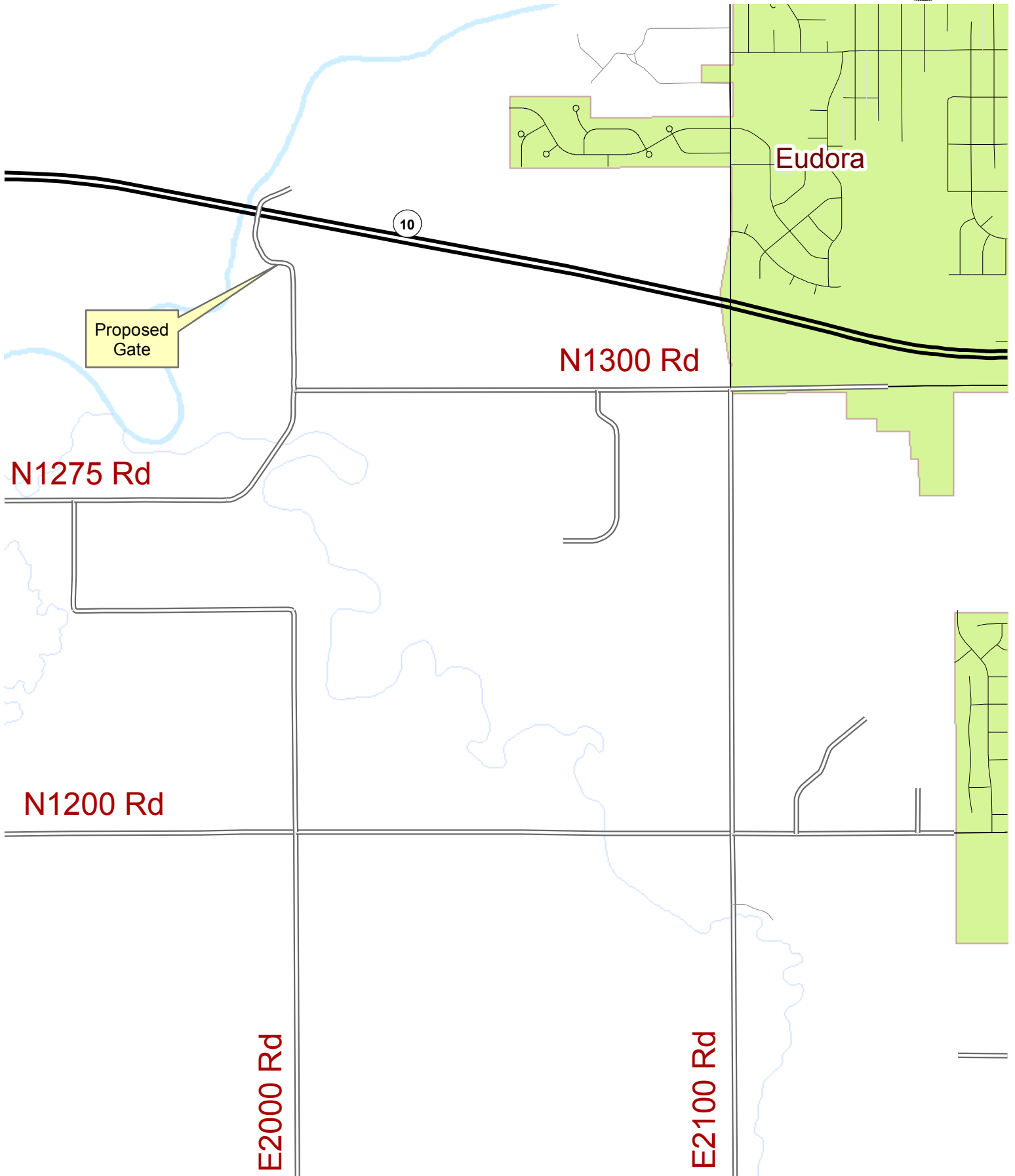
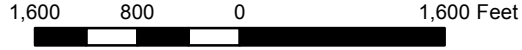

# Proposed Gate E2000 Road



1 inch = 300 feet

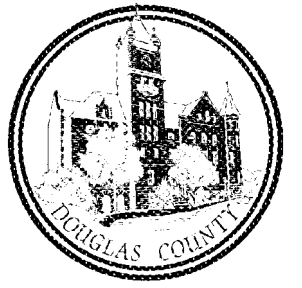
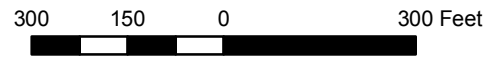



RESOLUTION NO. 2014 - \_\_\_\_\_

A RESOLUTION PROVIDING FOR THE INSTALLATION OF A GATE ON  
E2000 ROAD (PERMANENT ROAD RECORD NO. 359) IN EUDORA  
TOWNSHIP

WHEREAS, pursuant to K.S.A. 68-126, the board of county commissioners of any county are empowered to authorize and permit the construction and maintenance of fences and gates across public roads under their jurisdiction;

AND WHEREAS, the Board of County Commissioners of Douglas County, Kansas has determined there is a need for a gate to be placed on E2000 Road for the purpose of restricting travel thereon to those with a legitimate need and to reduce unlawful activities within the right-of-way;

AND WHEREAS, the surrounding lands are used largely as pasture lands by the adjacent owners and the convenience of the traveling public will not be materially affected by the placement of a gate across said road at the location described to-wit:

Approximately 1,500 feet north and 45 feet west of the southeast corner of Section 12, Township 13 South, Range 20 East of the Sixth Principal Meridian; and,

BE IT NOW THEREFORE RESOLVED by this Board of County Commissioners of Douglas County, Kansas that a gate may be placed at the above described location, provided that:

1. If the gate is locked a key will be provided to:
  - a.) The Eudora Township Trustee;
  - b.) The Eudora Township Fire Department;
  - c.) The Douglas County Sheriff;
  - d.) The Kansas Department of Transportation;
  - e.) Any affected landowner requiring access to his/her property;
  - f.) Any other citizen upon proof of legitimate need for access; and,
2. A sign be erected and maintained at said gate stating the authority for the installation of said gate and to provide guidance for gaining access; and,
3. Sixteen (16) square feet of red and white reflective material shall be placed and maintained on said gate immediately upon erection.
4. The Douglas County Public Works Department shall routinely inspect and perform required maintenance to the gate.

ADOPTED this \_\_\_\_\_ day of \_\_\_\_\_, 2014.

BOARD OF COUNTY COMMISSIONERS  
OF DOUGLAS COUNTY, KANSAS

\_\_\_\_\_  
Nancy Thellman, Chairman

ATTEST:

\_\_\_\_\_  
Mike Gaughan, Member

\_\_\_\_\_  
Jamie Shew, County Clerk

\_\_\_\_\_  
Jim Flory, Member